

MCCULLOCH[®]

CHIPPER/SHREDDER

Pro-Mac 5000
Pro Mac 5000i

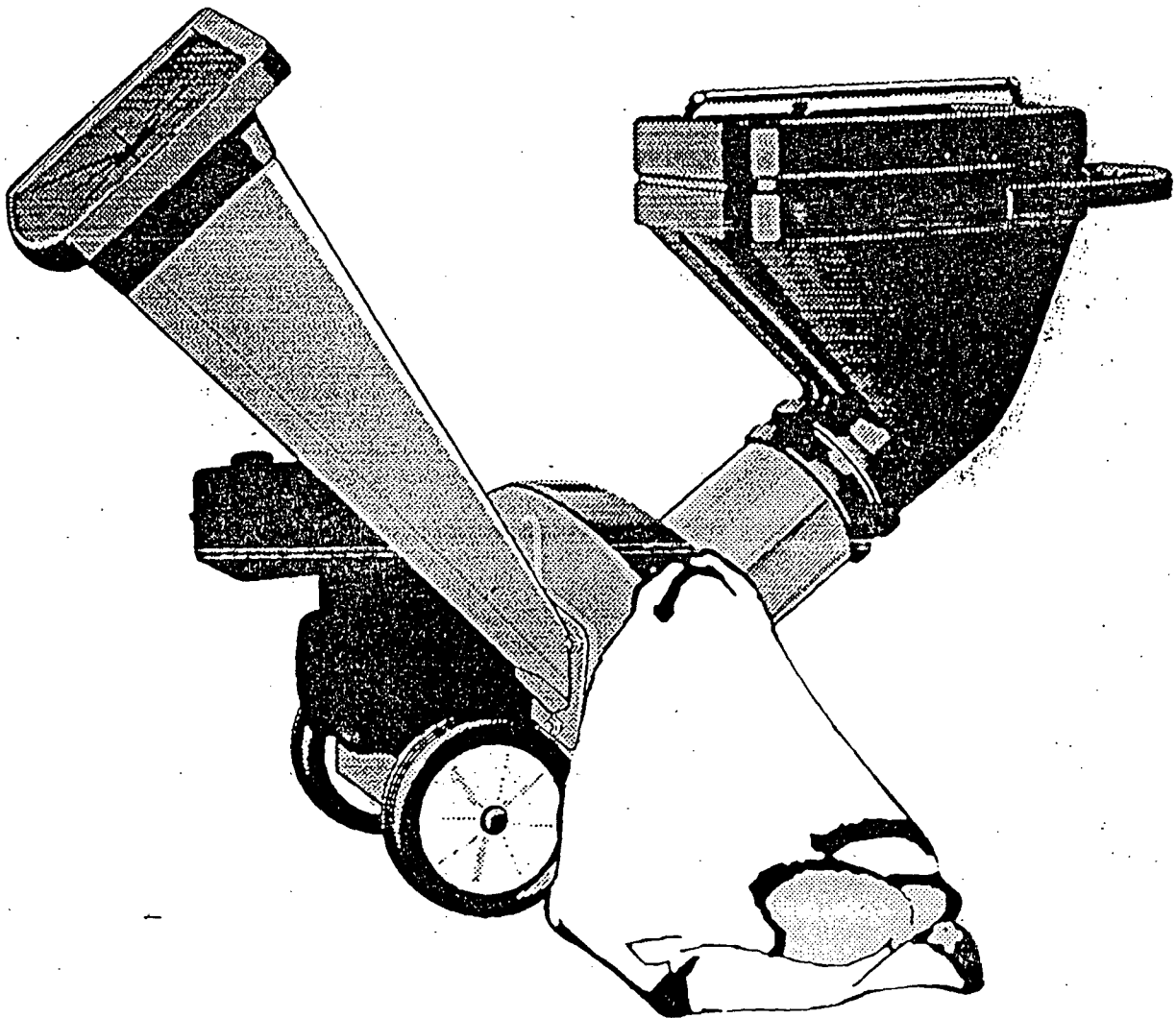

UK OWNER'S MANUAL

READ CAREFULLY

SAFETY RULES



WARNING: TO REDUCE THE POTENTIAL FOR ANY INJURY, COMPLY WITH THE FOLLOWING SAFETY INSTRUCTIONS. FAILURE TO COMPLY WITH THE INSTRUCTIONS MAY RESULT IN PERSONAL INJURY.

TRAINING

Read this owner's manual carefully in its entirety before attempting to assemble or operate this machine. Be completely familiar with the controls and the proper use of this machine before operating it. Keep this manual in a safe place for future and regular reference or for ordering replacement parts.

Children must never be allowed to operate this equipment.

No one should operate this unit while intoxicated or while taking medication that impairs the senses or reactions.

This equipment should never be operated in the vicinity of children, pets or other persons.

Never run your machine in an enclosed area as the exhaust from the engine contains carbon monoxide, which is an odorless, tasteless and deadly poisonous gas. Never place your hands or any part of your body or clothing inside the feeding chamber, discharge chute, or near any moving part while the machine or engine is running.

If it is necessary for any reason to inspect or repair the feeding chambers or any part of the machine where a moving part can come in contact with your body or clothing, stop the machine, allow it to cool, disconnect the spark plug wire from the spark plug and move it away from the spark plug before attempting such inspection or repair.

PREPARATION

Wear safety goggles, work gloves and shoes while operating the chipper/shredder. Do not wear loose clothing or jewelry.

Operate chipper/shredder only on a level surface.

Do not operate the chipper/shredder on a paved or gravel surface.

Before starting the chipper/shredder, check that all screws, nuts, bolts and all other fasteners are properly secured. Replace all damaged or unreadable warning and operating decals.

Check fuel level before starting engine. Gasoline is highly flammable; handle with care. Use only an approved container.

Do not fill fuel tank indoors, when engine is running, or until engine is allowed to cool. Do not smoke.

Reinstall fuel cap on tank and fuel container. Wipe the unit clean of any spilled fuel.

OPERATION

Before starting the machine, operators shall make certain that the cutting chamber is empty.

When feeding material into this equipment, be extremely careful that pieces of metal, rocks, bottles, cans or other foreign objects are not included. Personal injury or damage to the machine could result.

- If the cutting mechanism strikes any foreign object or if your machine should start making an unusual noise or vibration, immediately stop the engine, disconnect the spark plug wire from the spark plug and move it away from the spark plug. Allow the machine to stop and take the following steps:

Inspect for damage.

Replace or repair any damaged parts.

Check for any loose parts and tighten to assure continued safe operation.

- The engine must be kept clean of debris and other accumulations.
- Do not allow an accumulation of processed material to build up in the discharge area as this will prevent proper discharge and can result in kick-back from feed opening.
- Never place your hands or any other part of your body or clothing inside the feeding chamber, discharge chute or near any moving part while the engine is running.
- Keep all guards and deflectors in place and in good working condition to assure continued safe operation.
- Always stand clear of the discharge area when operating this machine.
- Keep your face and body back from the feed opening to avoid accidental bounce back of any material.
- Do not over-reach. Keep proper balance and footing at all times.
- The engine governor settings on your machine must not be altered, changed, or tampered with. The governor controls the maximum safe operating speeds and protects the engine and all moving parts from damage caused by over-speed. Authorized service personnel should perform these adjustments if a problem exist.
- Do not transport machine while engine is running.
- Do not operate engine if air cleaner or cover directly over carburetor air intake is removed, except for adjustment. Removal of such parts could create a fire hazard.
- If chipper/shredder becomes clogged the operator must shut-off engine, and disconnect spark plug before clearing debris.

MAINTENANCE AND STORAGE

- When this equipment is stopped for servicing, inspection, storage or to change an accessory, make sure the spark plug wire is disconnected from the spark plug and moved away from the spark plug. The machine should be allowed to cool down before making such inspection, adjustments, service, etc. Maintain your machine with care and keep it clean for the best and continued safe operation. Authorized service shall be sought if a problem exists.
- Do not use flammable solutions to clean the air filter.
- When not in use, your machine should be stored out of the reach of children. Keep where gasoline fumes will not reach an open flame or spark. For long periods of storage, refer to the "Storage" section of this manual.

WARNING: This unit is equipped with an internal combustion engine and should not be used on or near any unimproved forest-covered, brush-covered or grass-covered land unless the engine's exhaust system is equipped with a spark arrester meeting applicable local or state laws (if any). If a spark arrester is used, it should be maintained in effective working order by the operator.

In the State of California the above is required by law (Section 4442 of the California Public Resources Code). Other states may have similar laws. Local laws apply on federal lands. A spark arrester for the mulcher is available through your nearest engine authorized service dealer.

TABLE OF CONTENTS

SAFETY RULES.....	2	STORAGE.....	10
TABLE OF CONTENTS.....	3	SERVICE & ADJUSTMENTS.....	11-13
ASSEMBLY.....	4-5	TROUBLESHOOTING.....	14
OPERATION.....	6-8	REPAIR PARTS.....	15-23
MAINTENANCE.....	9	ACCESSORIES.....	24-29

ASSEMBLY

CONTENTS OF SHIPPING CARTON:

- 1 - Chipper/Shredder completely assembled except for chipper chute and shredder hopper
- 1 - Shredder hopper, handle and guard assembly
- 1 - Chipper chute assembly
- 1 - Deflector
- 1 - Parts Bag Containing:
 - 1 - Owners' Manual
 - 1 - Engine Manual
 - 1 - Warranty Card
- 10 - Patch Loc 1/4-20 x .50 One Way Screws
- 8 - Flatwashers .281x .63x .065
- 4 - Nuts 1/4-20 REGHEX Center lock
- 1 - Safety Goggles
- 1 - Collector Bag
- 1 - Debris Tamper

TOOLS REQUIRED FOR ASSEMBLY:

- 1- Regular Screwdriver
- 1-1/2" Wrench
- 1-1/2" Socket
- 1- Ratchet Wrench W/extension

NOTE: Tools required will depend on unit purchased.

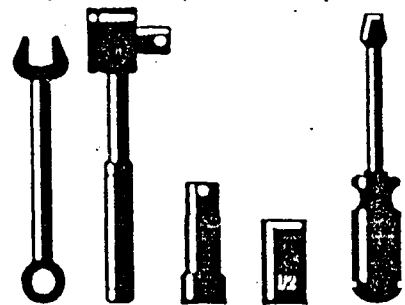
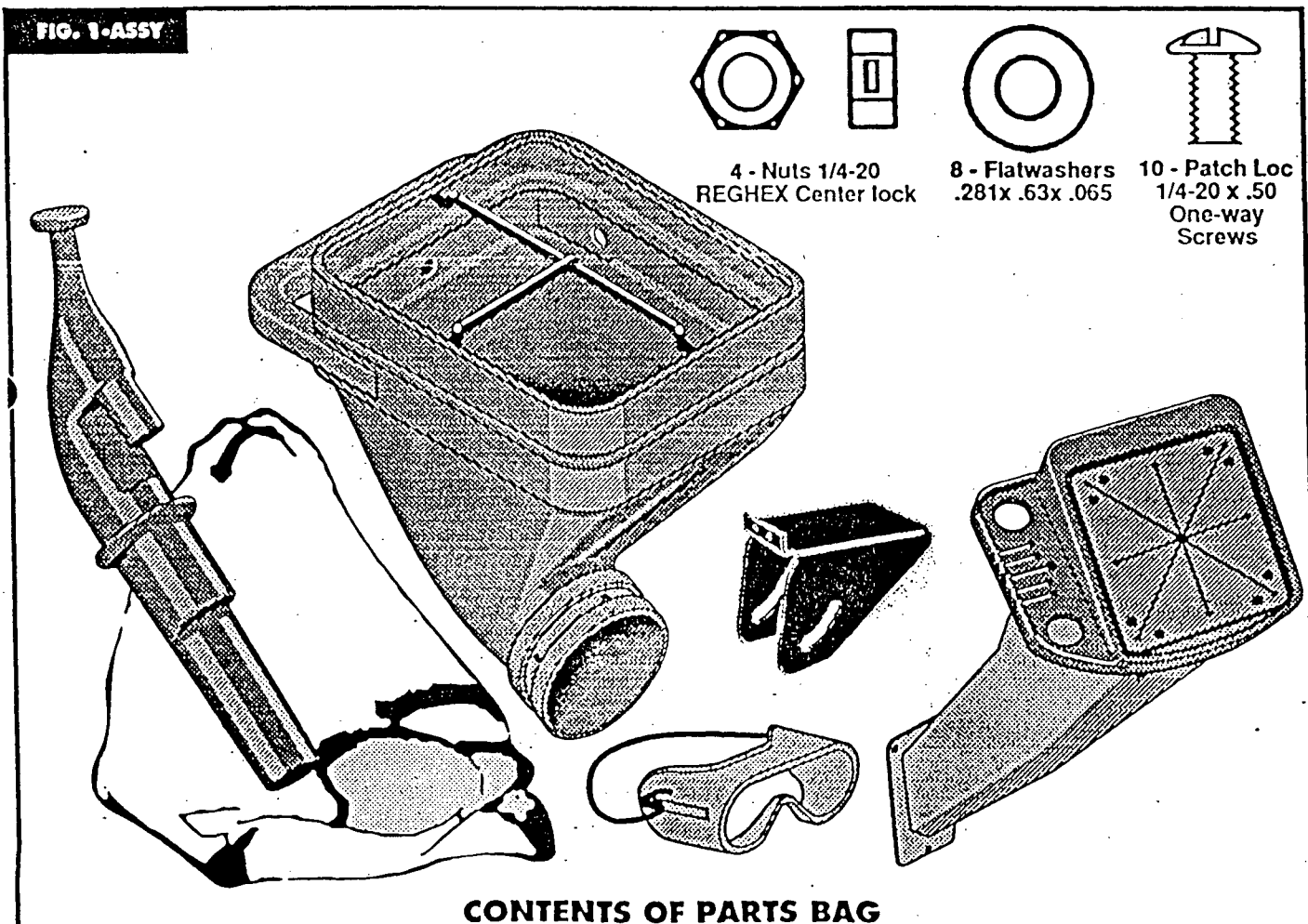

FIG. 1-ASSY



CONTENTS OF PARTS BAG

ASSEMBLY



DANGER



There are rotating cutting blades inside the Chipper/Shredder housing that will cause serious injury. DO NOT operate machine unless Chipper Chute and Shredder Hopper are securely installed.

STEP 1: UNPACKING AND CHECKING CONTENTS

Locate and remove Chipper Chute/Shredder Hopper assembly and debris tamper from carton.

Locate and remove parts bag.

Cut all four corners of carton from top to bottom and lay flat.

Remove bracket from support and cut nylon ties from axle.

Pull the Chipper/Shredder off of the pallet.

Properly dispose of discarded carton and pallet.

Compare contents with the contents of parts bag. If any parts are missing or damaged, contact your local service dealer or call for factory service.

STEP 2: INSTALL SHREDDER HOPPER

Rotate Shredder/Hopper tube upward to latched position.

With Shredder Hopper handle (item B) pointing away from the engine and the rectangular opening facing upward, position the round opening of the Shredder Hopper (item A) over the round steel chute tube (item D) (See FIG. 2-ASSY).

Align top hole in the Shredder Hopper neck with the top hole in the steel chute tube.

- Assemble six (6) 1/4-20 x .50 screws, provided in parts bag, through aligned holes. Do not tighten.
- Position Hopper in position level with the unit and tighten all six (6) screws securely.

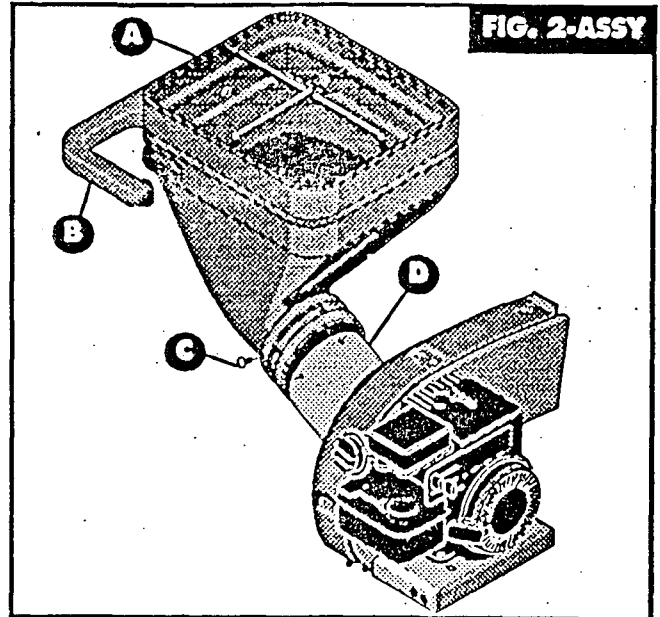

STEP 3: INSTALL CHIPPER CHUTE

- Remove flatwashers and locking nuts (item B) from the three (3) threaded studs (See FIG. 3-ASSY).
- Position Chipper Chute assembly (item A) in opening in housing and over the three (3) threaded studs. Place v-shaped bottom lip of Chipper Chute into opening first and raise Chipper Chute until remaining two (2) studs are through the top holes.
- Assemble flat washers and locking nuts to three (3) threaded studs and fasten securely.

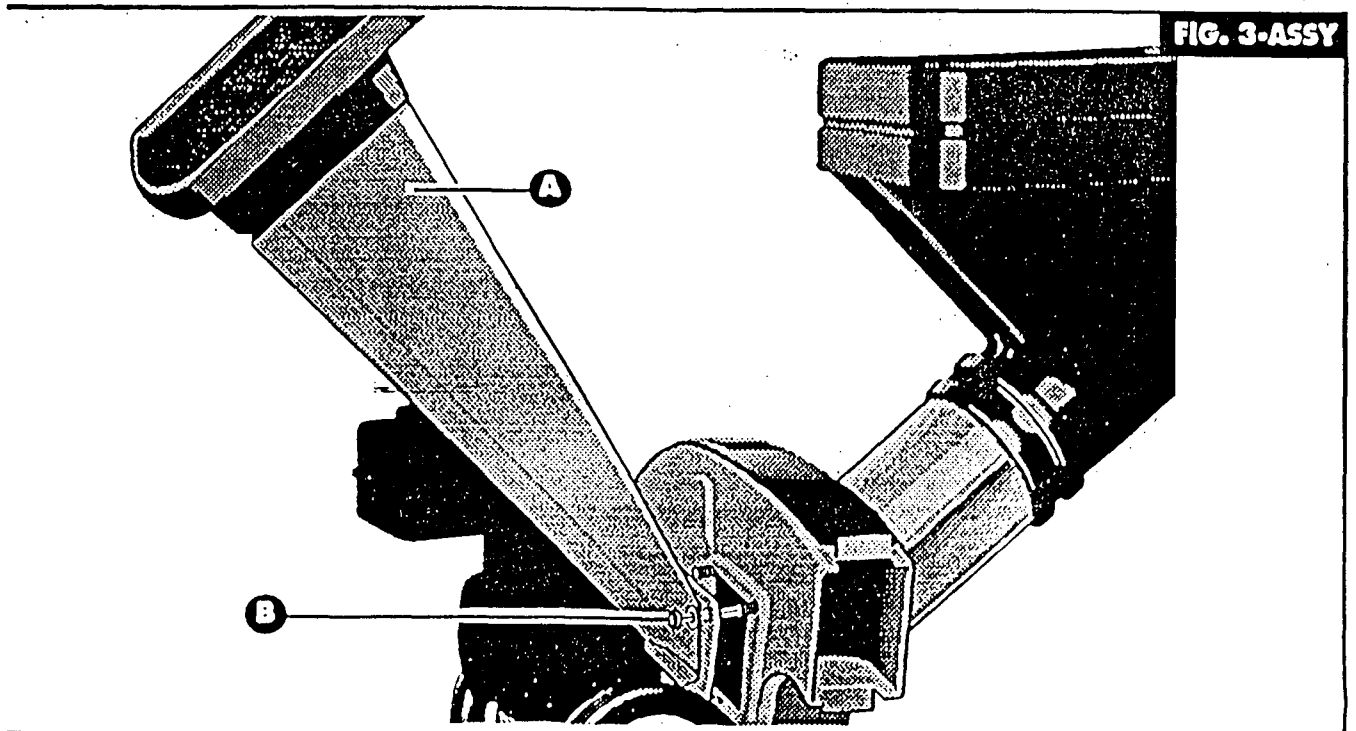

ASSEMBLY

STEP 4: INSTALL DISCHARGE DEFLECTOR

- Position discharge deflector (item C) as shown in FIG. 4-ASSY.
- Attach deflector to shredder housing using the four (4) 1/4-20 x .50 one-way screws (item D), eight (8) flatwashers (item E), and four (4) locknuts (item F). (See FIG. 4-ASSY)
- Tighten locknuts securely.

FIG. 4-ASSY

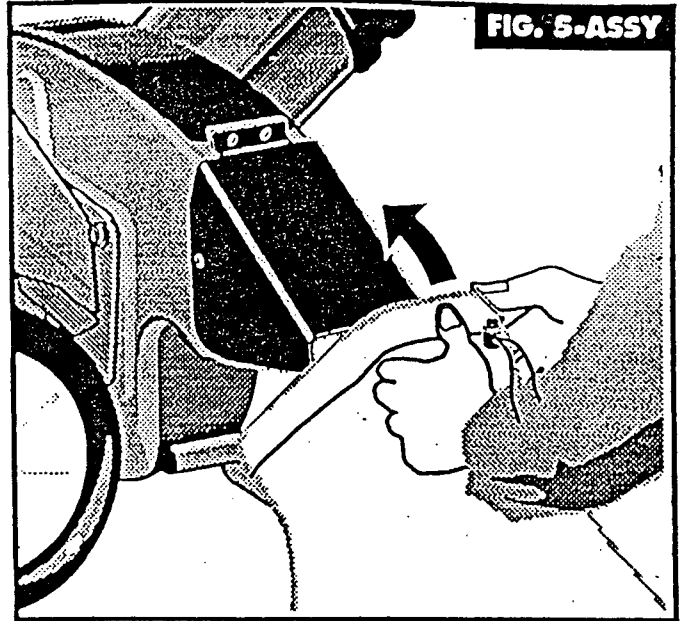
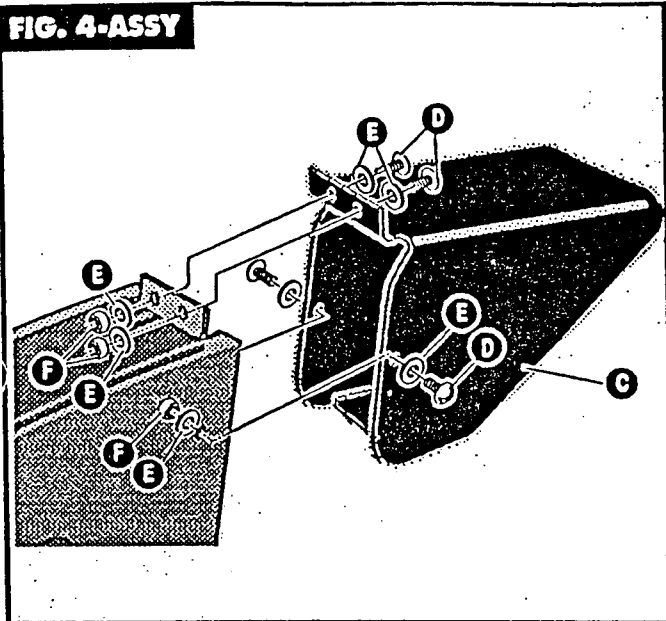

FIG. 5-ASSY

STEP 5: ASSEMBLY OF COLLECTOR BAG

The Chipper/Shredder comes equipped with one of two types of collector bag to catch the shredded material.

- To attach the bag, place the opening of the bag around the discharge opening (on units having a chute deflector, pull the bag over the deflector) until the drawstring is positioned behind upper and lower tabs on housing. Depress the plunger on the drawstring lock and pull on the drawstring until the bag is tight around the discharge opening. Release plunger to retain drawstring and bag in position. See FIG. 5-ASSY.
- The Chipper/Shredder may be operated without collector bag installed. When operating without bag, stay clear of discharge opening and do not allow material to collect and restrict discharge of material.

OPERATION

VIEW YOUR CHIPPER-SHREDDER

READ THIS OWNER'S MANUAL AND SAFETY RULES BEFORE OPERATING YOUR CHIPPER-SHREDDER. Compare the illustrations with your chipper-shredder to familiarize yourself with the location of various controls and adjustments. Save this manual for future reference.

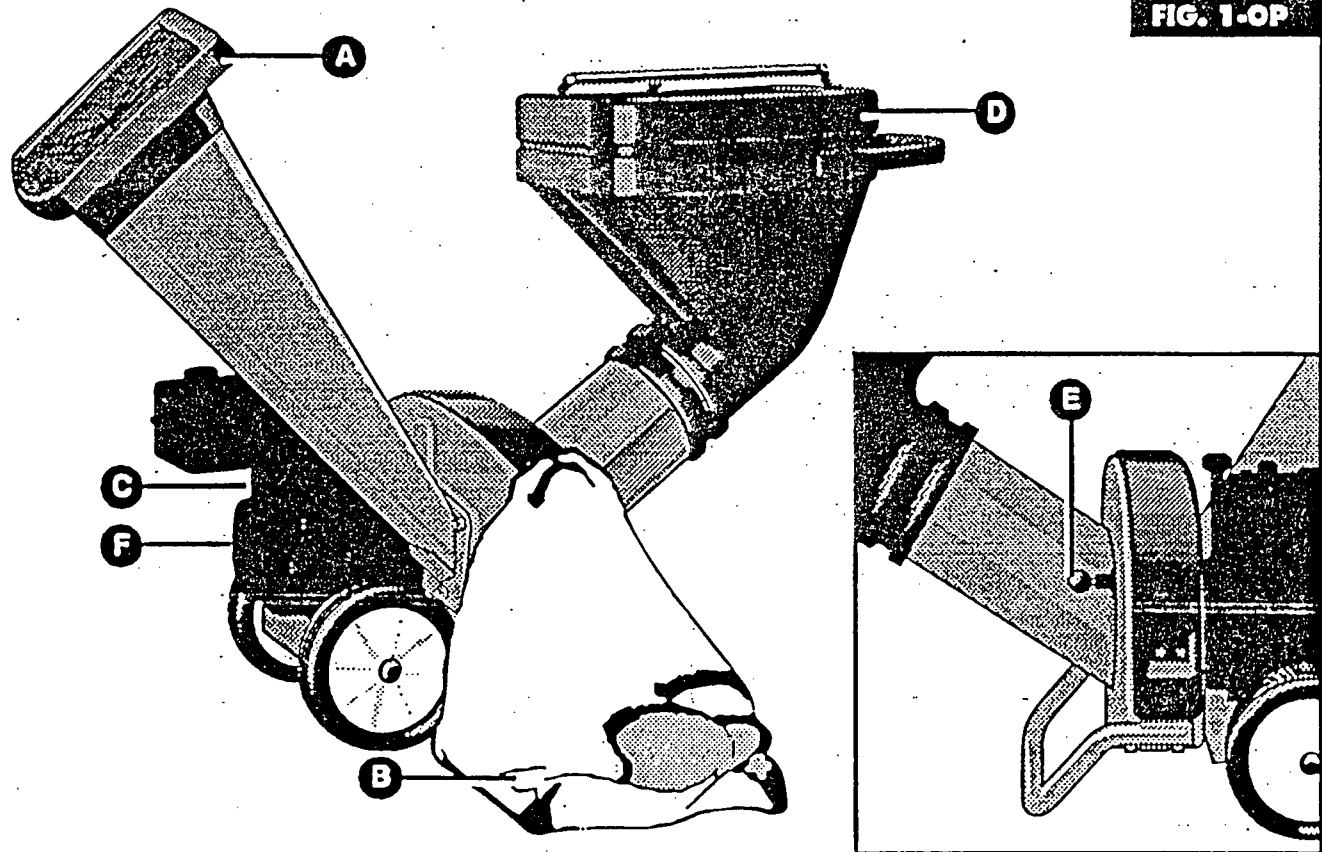

MEETS ANSI SAFETY STANDARDS

Chipper-Shredders conform to the safety standards of the American National Standards Institute.

OPERATING CONTROLS (SEE FIG. 1 OP)

CHIPPER CHUTE - Used for chipping branches

COLLECTOR BAG - Used to collect all chipped, shredded accumulated debris for easy disposal.

ENGINE CONTROLS - Throttle and Choke controls are located here. (see engine manual for individual controls)

(D) SHREDDER HOPPER - Used for shredding small branches and other small debris.

(E) SHREDDER HOPPER RELEASE KNOB - Releases Shredder Hopper to rotated to ground position for easy raking of leaves and other debris into the hopper.

(F) STARTER HANDLE - Used to manually start the engine.

BEFORE USING YOUR CHIPPER-SHREDDER, AGAIN REFER TO THE "SAFETY RULES" AS SHOWN ON PAGE 2 OF THIS MANUAL. ALWAYS BE CAREFUL.

Maximum noise level measured in a distance of 1m from shredder and 1.6m above ground = 97db(A) (as per 45635).



The operation of any chipper-shredder can result in foreign objects being thrown into the eyes, which can result in severe eye damage. Always wear safety glasses or eye shields while chipping or shredding, or performing any adjustments or repairs. We recommend Wide Vision Safety Mask for over spectacles or standard glasses.

OPERATION

BEFORE STARTING

1. Place the shredder on a firm, level surface.
2. Service engine with gasoline and oil as instructed in the separate engine manual packed with your shredder.
3. Insure spark plug wire is attached to spark plug.



DANGER



BE SURE NO ONE OTHER THAN THE OPERATOR IS STANDING NEAR THE CHIPPER-SHREDDER WHILE STARTING OR OPERATING.



WARNING



THE CHIPPER/SHREDDER IS SHIPPED WITHOUT GASOLINE IN THE FUEL TANK AND VERY LITTLE OIL IN THE ENGINE CRANKCASE. DO NOT OPERATE ENGINE UNTIL CRANKCASE HAS BEEN FILLED WITH OIL AS SPECIFIED IN THE ENGINE MANUAL PROVIDED WITH THE MACHINE.

TO START ENGINE:

- Insure spark plug wire and rubber boot is attached to spark plug (See Engine Manual).
- Turn fuel shut-off valve to "ON" position (if so equipped) (see Engine Manual).
- Push stop switch to "ON" position (if so equipped).
- Move choke control lever to "CHOKE/FULL CHOKE" position. (See Engine Manual)
- Move throttle control lever to "FAST/ON/RUN" position.
- Grasp starter handle (See Engine Manual) and pull rope out slowly until engine reaches start of compression cycle (rope will pull slightly harder at this point. Let the rope rewind slowly).
- Pull the rope with a rapid, continuous, full arm stroke. Keep a firm grip on start handle. Let rope rewind slowly. DO NOT let starter handle snap back against starter.
- Repeat preceding two (2) instructions until engine fires. When engine starts, move choke lever on engine halfway between "CHOKE/FULL CHOKE" and "RUN/NO CHOKE".
- Move throttle control to idle position for a few minutes to allow engine to warm-up. When engine is warm move choke lever to "RUN" position.

NOTE: In order to idle smoothly, a new engine may require three (3) to five (5) minutes running above slow idle speed. Idle speed has been adjusted to be correct after this break-in period.

TO STOP ENGINE:

- Move throttle control lever to "OFF/STOP/SLOW" position. (See Engine Manual)
- Push stop switch to "OFF" position (if so equipped).
- Do not choke carburetor to stop engine. Backfire or engine damage may result if choke is used to stop engine.

NOTE: Close fuel shut off valve (if so equipped) when transporting or not operating Chipper/Shredder, to prevent fuel leakage.

HOW TO USE YOUR CHIPPER-SHREDDER:

The Chipper/Shredder is designed for three (3) different methods of operation.



DANGER



THE CHIPPER-SHREDDER DISCHARGES MATERIALS WITH CONSIDERABLE VELOCITY. KEEP AWAY FROM THE AREA AROUND THE DISCHARGE. ALWAYS STOP THE ENGINE AND DISCONNECT THE SPARK PLUG WIRE WHEN REMOVING OR ATTACHING THE BAG WHEN CHANGING CONTAINERS OR WHEN REMOVING THE SHREDDED MATERIAL. WEAR SAFETY GLASSES AND GLOVES WHENEVER USING YOUR CHIPPER-SHREDDER.

- Leaves and small branches can be fed into the Hopper assembly when it is in the raised position (See FIG. 2-OP). If it becomes necessary to push material into the Chipper/Shredder, use the supplied debris tamper - NOT YOUR HANDS.



DANGER



ANY ATTEMPT TO PUSH MATERIAL WITH ANYTHING OTHER THAN THE DEBRIS TAMPER CAN RESULT IN PERSONAL INJURY AND/OR MACHINE DAMAGE.

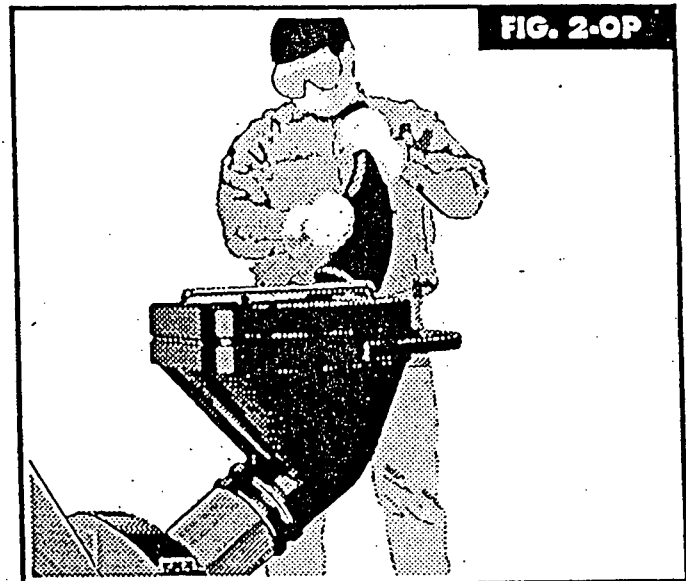

OPERATION



WARNING



DO NOT DEPOSIT MATERIAL LARGER THAN 1/2" DIAMETER IN THE HOPPER ASSEMBLY. ANY MATERIAL HEAVIER THAN 1/2" SHOULD BE FED INTO THE CHIPPER CHUTE.

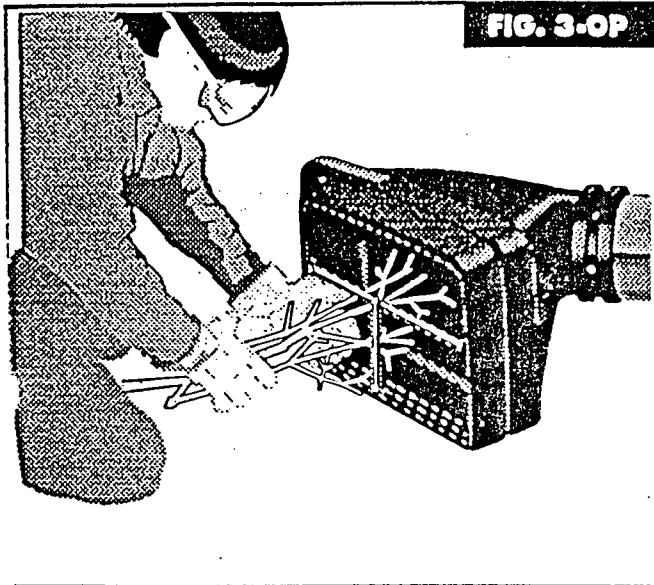

- Leaves and small twigs can be raked into the Hopper assembly, when the Hopper assembly is rotated to the ground. Small branches can also be fed into the Hopper assembly in this position (See FIG. 3-OP).

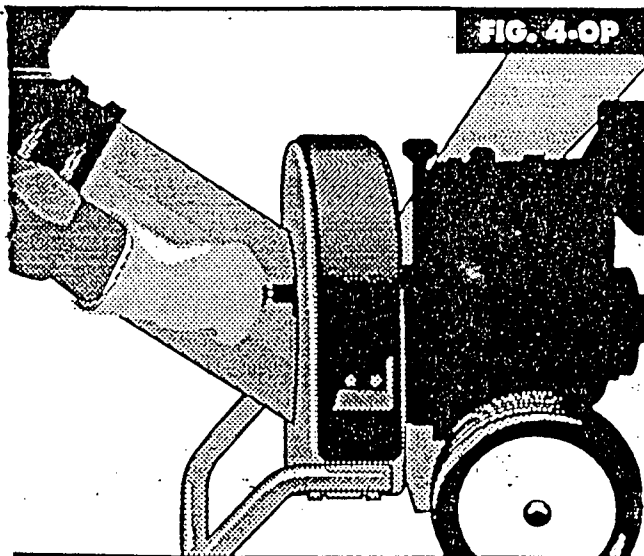

- To rotate the Hopper assembly, use one (1) hand to pull the Hopper release knob out until the Hopper assembly is free to move (See FIG. 4-OP). Rotate the Hopper assembly to the right (while holding the Hopper release knob) until the edge contacts the ground.



DANGER



MAKE CERTAIN THE CHIPPER CHUTE GUARD IS IN PLACE. SHOULD THE CHIPPER CHUTE GUARD BECOME WORN OR TORN, REPLACE BEFORE CONTINUING USE.

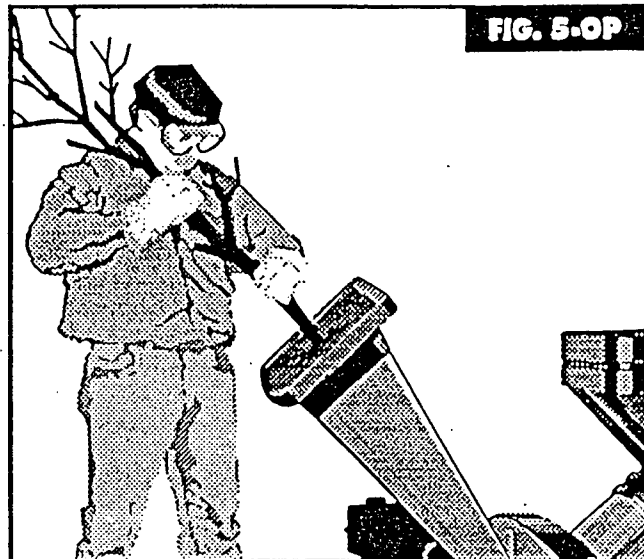

- Bulky material, such as stalks or heavy branches (anything over 1/2" diameter, up to 3" in diameter), should be fed into the Chipper chute (See FIG 5-OP).

For best performance, it is important to keep the shredding blade and the chipper blade sharp. Refer to service and adjustment section, pages 12, 13. If the composition of the material being discharged changes (becomes stringy, etc.) or if the rate at which the material feeds in slows down considerably, it is likely that the shredding blade and/or Chipper blade is dull and need to be sharpened or replaced.

MAINTENANCE



DANGER



ALWAYS STOP ENGINE AND DISCONNECT SPARK PLUG WIRE BEFORE CLEANING, LUBRICATING OR PERFORMING ANY REPAIRS OR MAINTENANCE.

GENERAL RECOMMENDATIONS:

- Periodically check all fasteners and be sure they are tight.
- Follow the Service Recommendation Schedule, in **SERVICE AND ADJUSTMENT** section of this manual.

CHIPPER/SHREDDER LUBRICATION:

- Lubricate the transport wheel hubs occasionally, with a good quality motor oil.
- The rotating Hopper assembly requires lubricating to maintain optimum performance. Approximately every five (5) hours of operation, before each use, and before storage, lubricate the Hopper assembly rotating plate. Using a hand grease gun, filled with a good quality, all-purpose grease, lubricate the three (3) zerk fittings found on the Hopper assembly retainer ring.
- Fill each zerk with approximately five (5) shots of grease. Rotate Hopper assembly to the ground as shown in FIG.5-OP and apply five (5) more shots of grease to each of the three (3) zerks. Rotate Hopper assembly several times to spread lubricant around. **NOTE:** Should lubricating the Hopper assembly fail to provide adequate rotation, remove the entire Hopper assembly from unit (See FIG.2-SERV). Clean debris from all rotating parts, replace or repair any damaged parts, reassemble Hopper assembly securely to unit and lubricate according to procedure above.
- Caster wheel (optional) approximately every ten (10) hours of operation and before storage, lubricate the zerk fitting found above the caster wheel with three (3) shots of a good quality, all purpose grease.

ENGINE LUBRICATION:

Refer to the separate engine manual for engine maintenance instructions. Maintain engine oil as instructed in the separate engine manual packed with your unit. Read and follow instructions carefully.

AIR CLEANER

Service air cleaner every (25) hours or every season, which ever comes first. Clean every few hours under extremely dusty conditions. Poor engine performance and flooding usually indicates that the air cleaner should be serviced. To service the air cleaner, refer to the separate engine manual packed with your unit.

NOTE: Never run your engine without air cleaner completely assembled.

FUEL FILTER (IF SO EQUIPPED)

Fuel filter should be replaced once each season. If fuel filter becomes clogged, obstructing fuel flow to carburetor, replacement is required. To service the air cleaner, refer to the separate engine manual packed with your unit.

SPARK PLUG

The spark plug should be cleaned and the gap reset once a season or every (50) hours of operation (See Engine Manual) Spark plug replacement is recommended at the start of each season; check engine manual for correct plug type and gap specifications.

CLEAN ENGINE

Clean engine periodically. Remove dirt and debris with a cloth or brush. Cleaning with a forceful spray of water is not recommended as water could contaminate the fuel system. Yearly or every twenty-five (25) hours, which ever occurs first, remove the blower housing and clean the areas shown in your Engine Manual to avoid over-speeding, over-heating and engine damage. Clean more often if necessary.

MUFFLER

Do not operate the Chipper/Shredder without a muffler or tamper with the exhaust system. Damaged mufflers or spark arresters could create a fire hazard. Inspect periodically and replace if necessary. If your engine is equipped with a spark arrester screen assembly, remove every fifty (50) hours for cleaning and inspection. Replace if damaged.

CLEANING

- The Chipper/Shredder may be cleaned by running water from a hose through the Shredder Hopper assembly and Chipper chute with engine running. Allow the Chipper/Shredder to dry thoroughly.
- Wash the bag periodically with water. Allow to dry thoroughly in the shade. **Do Not** use heat.

STORAGE



DANGER



NEVER STORE YOUR CHIPPER-SHREDDER INDOORS OR IN AN ENCLOSED, POORLY VENTILATED AREA IF GASOLINE REMAINS IN THE TANK. FUMES MAY REACH AN OPEN FLAME, SPARK OR PILOT LIGHT FROM A FURNACE, WATER HEATER, CLOTHES DRYER, CIGARETTE, ETC.

To prevent engine damage if chipper-shredder is not used for more than 30 days, follow the steps below:

NOTE: GASOLINE MUST BE REMOVED OR TREATED TO PREVENT GUM DEPOSITS FROM FORMING IN THE TANK, FILTER, HOSE AND CARBURETOR DURING STORAGE. ALSO DURING STORAGE, ALCOHOL-BLENDED GASOLINE THAT USES ETHANOL OR METHANOL (SOMETIMES CALLED GASOHOL) ATTRACTS WATER. IT ACTS ON THE GASOLINE TO FORM ACIDS WHICH DAMAGE THE ENGINE.

To remove gasoline, run engine until tank is empty and engine stops. If you do not want to remove gasoline, a gas stabilizer such as STA-BIL may be added to any gasoline left in the tank to minimize gum deposits and acids. If the tank is almost empty, mix stabilizer with fresh gasoline in a separate container and add some to the tank. Always follow instructions on stabilizer container. Then run engine at least 10 minutes after stabilizer is added to allow mixture to reach carburetor. Store chipper-shredder in safe place. See warning above.

The following steps should be taken to prepare your shredder for storage.

- Clean unit thoroughly, including engine.
- Refer to engine manual for correct engine storage instructions.
- Carefully inspect unit and replace any worn, damaged, or missing parts and tighten any loose fasteners
- If storing in an unventilated or metal storage shed, coat metal parts with a light oil or silicone to prevent rusting.
- Store Chipper/Shredder in a dry, clean area, out of the reach of children.

SERVICE AND ADJUSTMENT



DANGER



ALWAYS STOP ENGINE AND DISCONNECT SPARK PLUG WIRE AND MOVE IT AWAY FROM SPARK PLUG BEFORE PERFORMING ANY ADJUSTMENTS OR REPAIRS.

WHEN CLEANING, REPAIRING OR INSPECTING YOUR CHIPPER/SHREDDER MAKE CERTAIN ALL MOVING PARTS HAVE STOPPED.

TO REDUCE THE RISK OF INJURY, ALWAYS WEAR HEAVY GLOVES WHEN HANDLING THE CUTTING BLADES. THE CUTTING EDGES ARE SHARP AND CAN CAUSE SEVERE INJURY.

SHARPENING OR REPLACING CHIPPER BLADES:

Over a period of time, the cutting blade will dull. Sharpen or replace the blade when the chipper no longer cuts as efficiently as when new.

- Discard a cracked or severely nicked blade because it could break apart and cause personal injury.
- Sharpen a blade that is dull or that has only minor nicks. The blade is made from tempered steel and is extremely hard - do not attempt to sharpen with a hand file. We recommend that you take the blade to a professional sharpening service for proper sharpening. All grinding must be done flat and uniform along the beveled edge only, being sure to maintain the original 45° cutting angle.

TO REMOVE AND INSTALL THE CHIPPER BLADE:

- Disconnect spark plug wire and move it away from spark plug.
- Remove the Chipper chute by removing three (3) hex nuts and washers (items B). A 1/2" socket with extension is required (See FIG.-3 ASSY).
- Rotate the Hopper assembly to the ground as shown in FIG. 3-OP.
- Remove the three (3) hex locknuts (item A) and flatwashers (item B) from the housing studs and carefully separate the Hopper assembly from the remainder of the unit (See FIG. 2-SERV. & ADJ.).
- Remove the three (3) bushings (item C) and stationary plate (item D). (See FIG. 2-SERV. & ADJ.) NOTE: When reassembling, make certain the opening of the stationary plate is toward the bottom of the unit and the offset, is facing toward the impeller assembly.
- Rotate the impeller assembly by hand until you locate the Chipper blade in the Chipper chute opening.
- Prevent the impeller assembly from turning in a counterclockwise direction by wedging a block of wood between one of the fan blades and the wall of the housing or, insert a thick, hardwood dowel (item A) through the slot below the blade and into the Chipper chute opening in the wall of the housing. (See FIG. 1-SERV & ADJ).

- Remove the blade, using a 3/16" allen wrench (item B) on the outside of the blade and 1/2" wrench (item C) on the impeller assembly (inside the housing) (See FIG. 1-SERV & ADJ).
- Replace or sharpen blade. Reassemble in reverse order making certain to install the blade with the sharp edge facing away from the impeller assembly and pointing toward the slot in the impeller assembly. Tighten locknuts securely (if using a torque wrench, tighten locknuts to 20 ft-lbs).

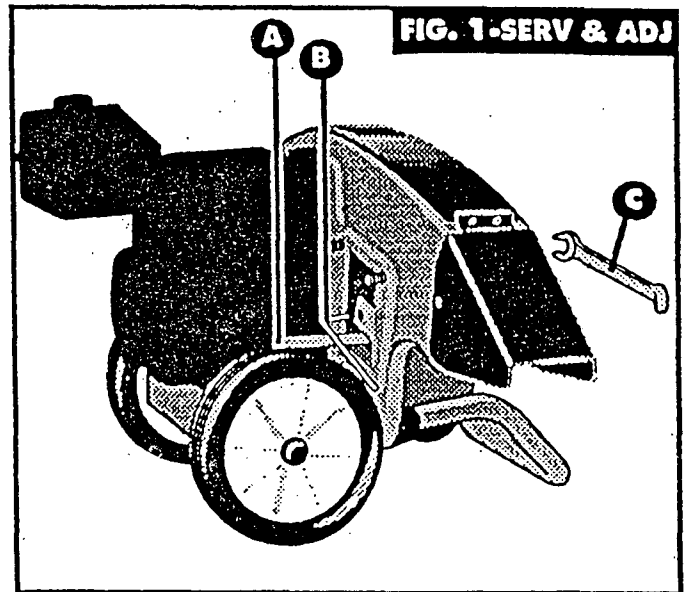

FIG. 1-SERV & ADJ

REVERSING, SHARPENING, OR REPLACING SHREDDER BLADE:

- The shredding blade is reversible and can be reversed before any sharpening should need to be performed.
- After both sides of the blade have become dull, nicked, etc. to the point of reducing performance, the blade needs to be sharpened or replaced.

TO REMOVE AND INSTALL SHREDDING BLADE:

- Disconnect spark plug wire and move it away from spark plug.
- Rotate the Hopper assembly to the ground as shown in FIG. 3-OP.
- Remove the three (3) hex locknuts (item A) and flatwashers (item B) from the housing studs and carefully separate the Hopper assembly from the remainder of the unit (See FIG. 2- SERV & ADJ.).
- Remove the three (3) bushings (item C) and stationary plate (item D) (See FIG. 2- SERV & ADJ.) (NOTE: When reassembling, make certain the opening of the stationary plate is toward the bottom of the unit and the offset, is facing toward the impeller assembly).
- Prevent the impeller assembly from turning in a counterclockwise direction by wedging a block of wood between one of the fan blades and the wall of the housing.

SERVICE AND ADJUSTMENT

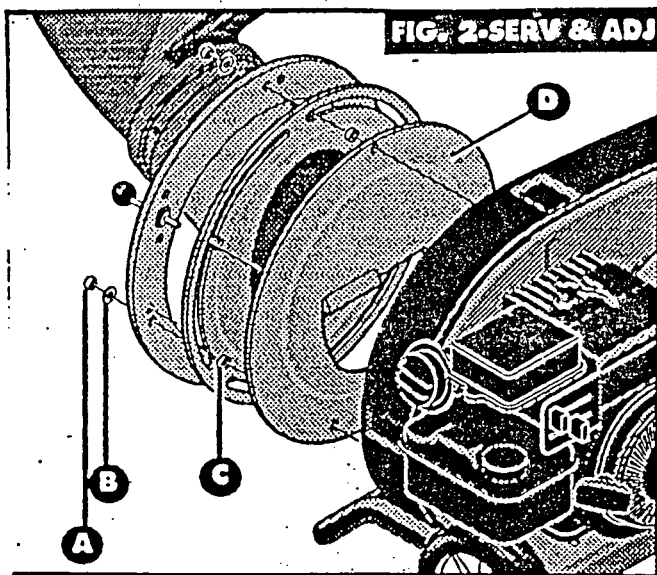

FIG. 2-SERV & ADJ

- Remove the impeller assembly (See FIG. 3-SERV & ADJ) by removing the center bolt, lockwasher, and spring washer (NOTE: When reassembling, make certain the raised side of the spring washer faces the bolt head).

NOTE: Use caution when removing the impeller assembly from the housing.

- Lay the impeller assembly on a solid, level surface with the shredding blade facing up.
- Using two (2) 1/2" wrenches, remove the shredding blade from impeller assembly by removing the blade retaining bolts, flatwashers and locknuts (SEE FIG. 3-SERV & ADJ).
- When sharpening the blade, follow the original angle of grind as a guide. It is extremely important that each cutting edge receives an equal amount of grinding to prevent an unbalanced blade. An unbalanced blade will cause excessive vibration when rotating at high speeds and may cause damage to the unit.
- The blade can be tested for balance by balancing it on a round shaft screwdriver or nail. Remove metal from the heavy side until it is balanced evenly (SEE FIG. 4-SERV & ADJ).
- When reassembling the shredding blade, tighten the blade retaining bolt nuts to 20 ft-lbs., or lacking torque wrench, tighten securely.

Before reinstalling impeller housing, thoroughly clean the housing chamber and the engine crankshaft. Apply a coating of fresh, good quality general purpose grease to the crankshaft.

Reinstall the key in the crankshaft keyway.

Align the keyway in the impeller assembly with the crankshaft key and carefully slide the impeller onto the crankshaft. Tighten the impeller assembly centerbolt to 45-50 ft-lbs. (Briggs Engines); 55-60 ft-lbs. (Tecumseh Engines); or lacking torque wrench, tighten securely.

Reassemble remainder of unit.

- Start the engine and listen for any unusual noise or vibration that could signal improper installation of the shredding blade or impeller assembly. If there is an unusual noise or vibration, stop the engine immediately and call the factory or contact your local authorized service dealer. Do not attempt to operate the machine until the problem has been corrected.

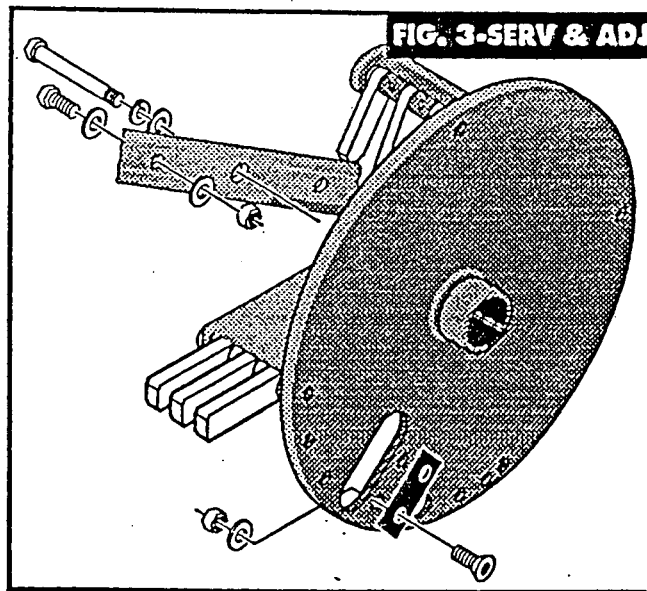

FIG. 3-SERV & ADJ

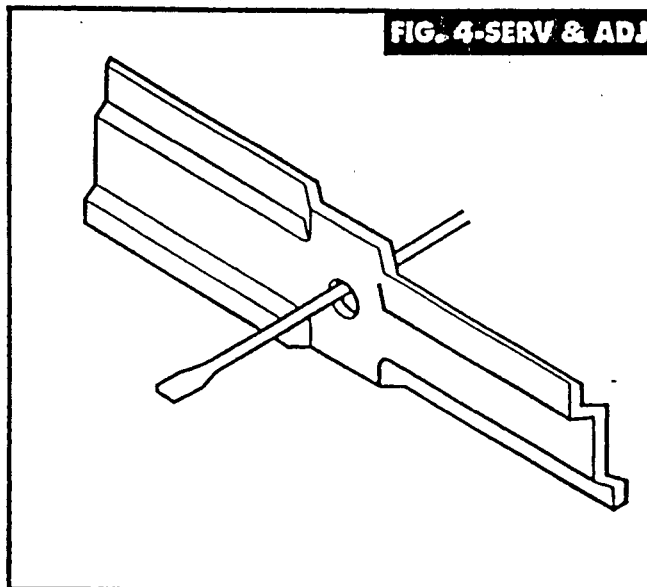

FIG. 4-SERV & ADJ

FLAILS

The flails are permanently attached and, under normal conditions, made to last the life of the unit. Should the flails become damaged, cracked or broken, contact your nearest service dealer for replacement.

SERVICE AND ADJUSTMENT

CARBURETOR ADJUSTMENT



DANGER



IF ANY ADJUSTMENTS ARE MADE TO THE ENGINE WHILE THE ENGINE IS RUNNING (E.G. CARBURETOR), KEEP CLEAR OF ALL MOVING PARTS. BE CAREFUL OF HEATED SURFACES AND MUFFLER.

Minor carburetor adjustment may be required to compensate for differences in fuel, temperature, altitude or load.

NOTE: A dirty air cleaner will cause engine to run rough. Be certain air cleaner is clean and attached to the carburetor before adjusting carburetor. Do not make un-necessary adjustments. Factory settings are satisfactory for most applications and conditions. If adjustment is needed, refer to the separate engine manual packed with your unit.

ENGINE SPEED

Your engine speed has been factory set. Do not attempt to increase engine speed or it may result in unit damage or personal injury. If you believe the engine is running too fast or too slow, take your Chipper/Shredder to the nearest Service Center for repair and adjustment.

SERVICE RECOMMENDATIONS

SERVICE RECORD Fill in dates as you complete regular service	SCHEDULE						SERVICE DATES						
	After First 5 Hours	Before Each Use	Every 25 Hours	Every 50 Hours	Beginning Each Season	Before Storage							
Check Fuel		√											
Drain Fuel						√							
Check Engine Oil Level		√			√								
Change Engine Oil	√		√			√							
Oil Pivot Points						√							
Service Air Cleaner			√			√							
Replace Fuel Filter					√								
Clean Engine Cylinder Fins			√			√							
Replace or Clean Spark Plug				√	√								
Spark Arrester Muffler				√									

The Service Recommendations Chart is supplied to assist the operator in proper maintenance of the chipper-shredder. This is only a check list; instructions will be found in the Maintenance and Service Adjustment sections of this manual.

TROUBLE SHOOTING

PROBLEM	POSSIBLE CAUSE (S)	CORRECTIVE ACTION
Engine fails to start	<ol style="list-style-type: none"> 1. Fuel tank empty, or stale fuel. 2. Spark plug wire disconnected. 3. Faulty spark plug. 4. Dirty fuel filter. (if so equipped) 	<ol style="list-style-type: none"> 1. Fill tank with clean, fresh fuel. 2. Connect wire to spark plug. 3. Clean, adjust gap or replace. 4. Replace fuel filter. (if so equipped)
Loss of power; operation erratically	<ol style="list-style-type: none"> 1. Spark plug wire loose. 2. Unit running on CHOKE. 3. Blocked fuel line or stale fuel. 4. Water or dirt in fuel system. 5. Carburetor out of adjustment. 6. Dirty air cleaner. 	<ol style="list-style-type: none"> 1. Connect and tighten spark plug wire. 2. Move choke lever to OFF position. 3. Clean fuel line; fill tank with clean fresh gasoline. 4. Disconnect fuel line at carburetor to drain fuel tank. Refill with fresh fuel. 5. Adjust carburetor or contact your Service Center. 6. Clean air filter.
Engine overheats	<ol style="list-style-type: none"> 1. Carburetor not adjusted properly. 2. Engine oil level low. 3. Engine cooling fins blocked. 	<ol style="list-style-type: none"> 1. Adjust carburetor or contact your Service Center. 2. Fill crankcase with proper oil. 3. Clear debris from fins.
Too much vibration	<ol style="list-style-type: none"> 1. Loose parts or damaged impeller 	<ol style="list-style-type: none"> 1. Stop engine immediately and disconnect spark plug wire. Tighten all bolts and nuts. Make all necessary repairs. If vibration continues, have unit service by a Service Center.
Units does not discharge	<ol style="list-style-type: none"> 1. Discharge chute clogged. 2. Foreign object lodged in impeller. 	<ol style="list-style-type: none"> 1. Stop engine immediately and disconnect spark plug wire. Clean inside of blower housing. See Service/Adjustments section of this manual. 2. Stop engine immediately and disconnect spark plug wire. Remove lodged object.

NOTE: For repairs beyond the minor adjustments listed above, please contact your nearest Service Center.

5 HP CHIPPER /SHREDDER PARTS D1705-100

MUFFLER GUARD ASSEMBLY

CRIMP LOOPS TO CLOSED POSITION

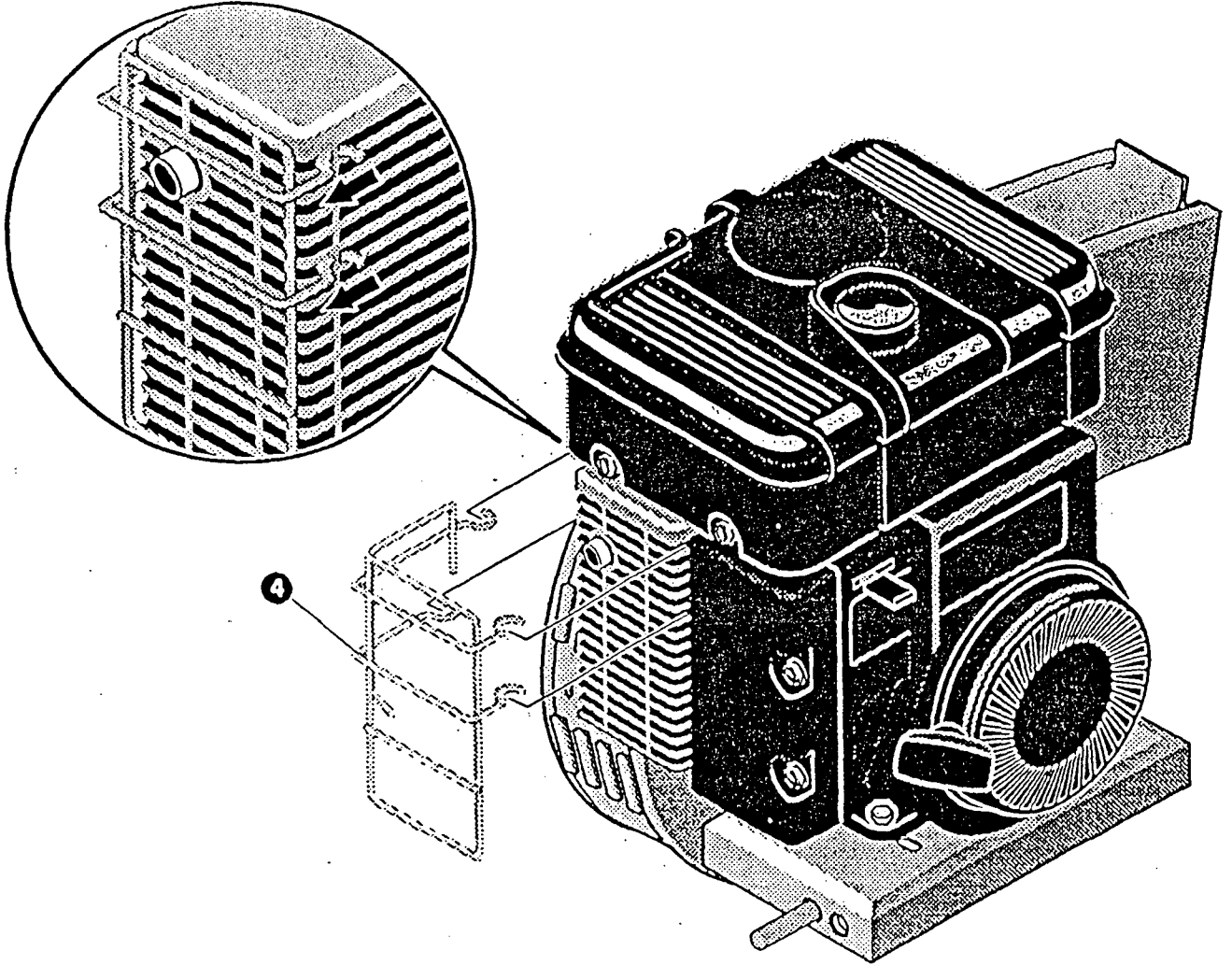

KEY #	PART #	DESCRIPTION
4	330438	MUFFLER GUARD EXT.

331123A-331124A

5 HP CHIPPER /SHREDDER PARTS D1705-100&130

5 HP

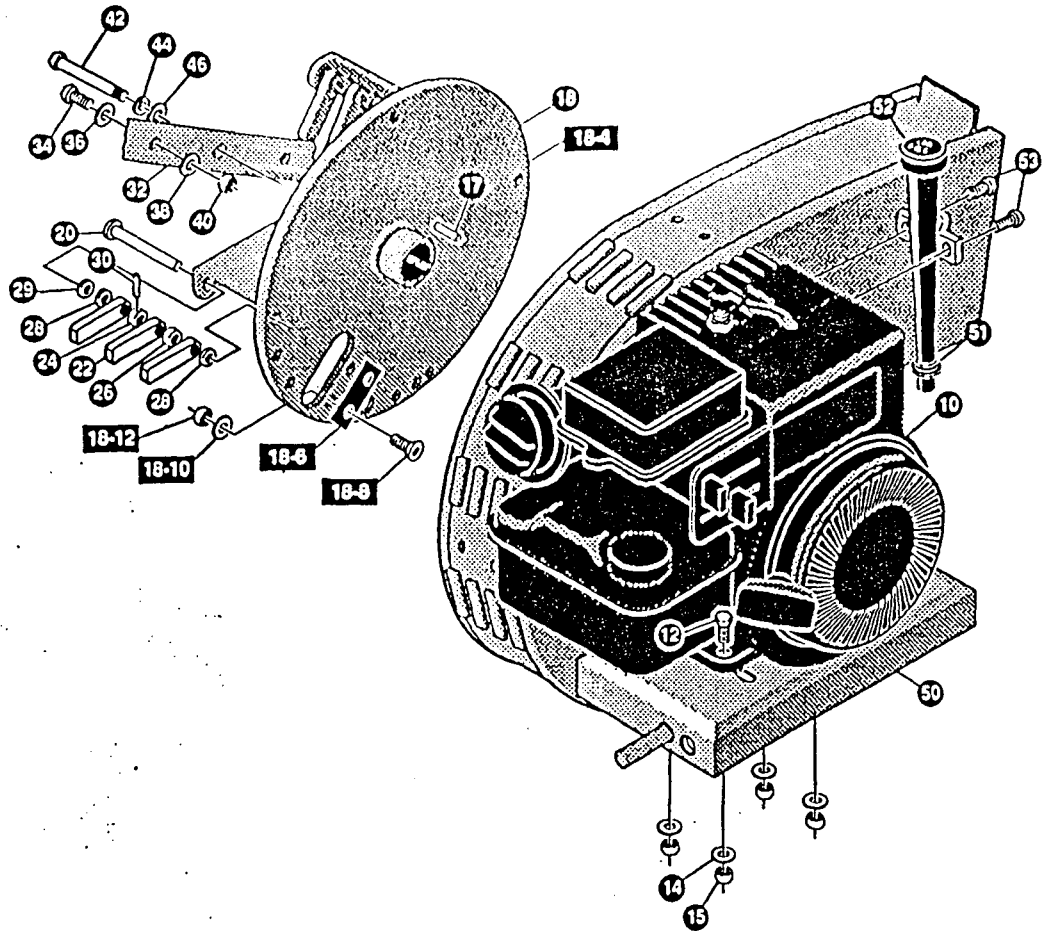

KEY #	PART #	DESCRIPTION
10		ENGINE, 5 HP B&S (SEE ENGINE MANUAL)
12	180083	SCREW, 5/16 -18X 1.50 IN. (D1705-100)
12	331216	SCREW, 5/16-18 X 1.50 IN. (D1705-130)
14	996407	FLATWASHER, .328 X .75 X .077 (D1705-100)
14	331308	FLATWASHER, .328 X .75 X .077 (D1705-130)
15	56845	NUT, 5/16-18 REGHCTRLK (D1705-100)
15	71391	NUT, 5/16-18 REGHEXCTRLK (D1705-130)
17	305562	KEY, SQUARE .250SQX2.12LG
18	327225	ASSEMBLY, FLAIL BALANCING NON-SERVICEABLE
18-4		
18-6	319661	BLADE, CHIPPER
18-8	323328	SCREW, 5/16-24 X 1.00
18-10	120638	WASHER, HVSPTLK .328 X .60 X .09
18-12	414072	NUT, 5/16-24 REGHCTRLK
20	323839	PIN, FLAIL .50 X 2.81
22	319660	FLAIL
24	319659	SPACER, SPEC .515 X 1.00 X .700
26	325463	SPACER, SLEEVE .515 X 1.00 X .700
28	56113	WASHER, FLAT .50 X .94 X .06
29	330517	FLATWASHER, .515 X 1.00 X .030
30	329416	RIVET, OVSET .188 X 1.094
32	319710	BLADE, ROTARY SHREDDER
34	180085	SCREW, 5/16-18 X 1.75
36	996407	WASHER, FLAT .328 X .75 X .077
38	2307	WASHER, FLAT .375 X .88 X .125
40	56845	NUT, 5/16-18 REGHCTRLK
42	326986	SCREW, 3/8-20 X 2.25 IN.
44	120382	WASHER, REGSPTLK .393 X .68 X .10
46	2483	WASHER, .391DX1.25DX.07 BELLVIL
50	327426-889	ENGINE MOUNT/AXLE ASSEMBLY
51	328386	TUBE & SEAL ASSY.
52	328387	DIPSTICK
53	50325	SCREW, 10-32 X .38 WAHHTAP
	330567	OWNER'S MANUAL, ENG
	330289	OWNER'S MANUAL, FR/GER

330373B-328242D
327142C-328242D

5 HP CHIPPER /SHREDDER PARTS D1705-100&130

WHEEL ASSEMBLY

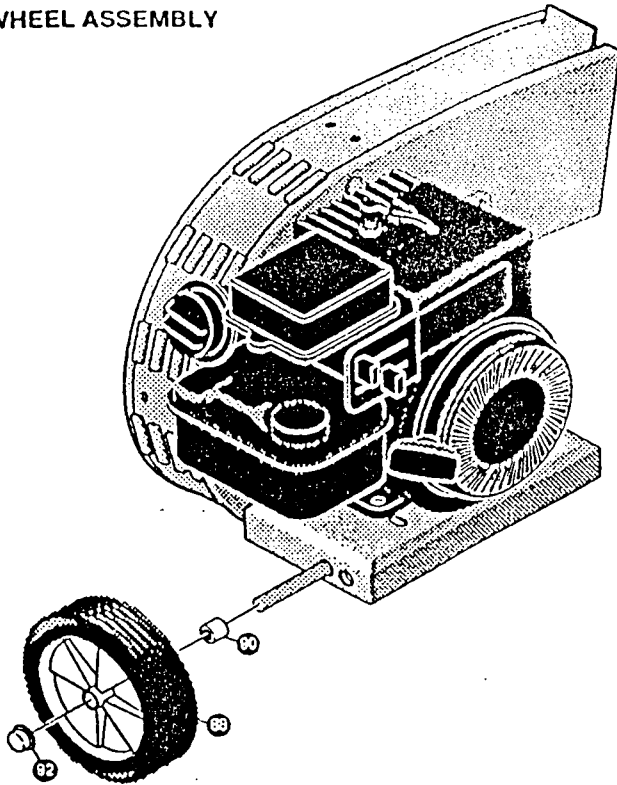

KEY #	PART#	DESCRIPTION
88	305508	TIRE & RIM SEPU 12X3
90	326863	SPACER, SLEV. 640X1.00X.688
92	323326	NUT, PUSH ON 5/8"

327212A-328815A

HOPPER ASSEMBLY

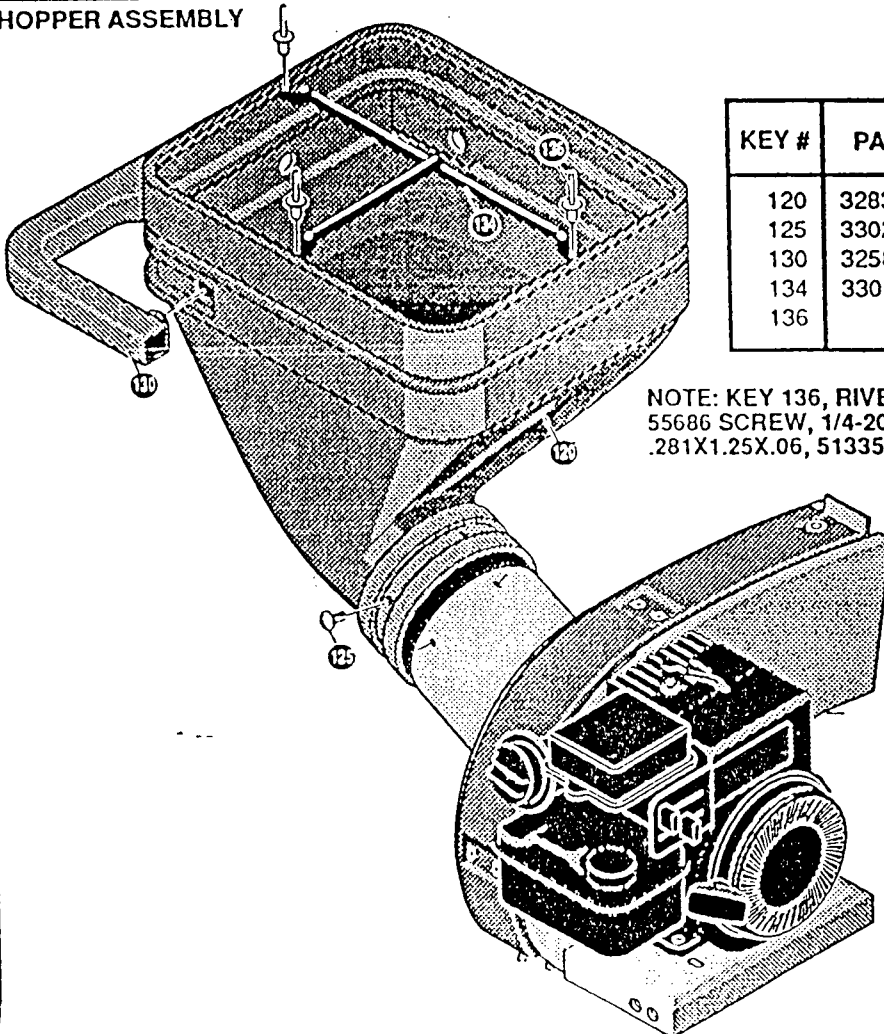

KEY #	PART#	DESCRIPTION
120	328341	HOPPER, DEBRIS
125	330205	SCREW, 1/4-20 X .50
130	325856	HANDLE, HOPPER
134	330166	GUARD, WIRE HOPPER
136		RIVET (NON SERVICEABLE)

330216A-330217A

NOTE: KEY 136, RIVET IS A NON-SERVICEABLE ITEM. ORDER 55686 SCREW, 1/4-20 X .63 SLTSRMA, 57626 FLATWASHER, .281X1.25X.06, 51335 NUT 1/4-20 WDFL WHIZ-LK.

5 HP CHIPPER /SHREDDER PARTS D1705-100&130

FLAIL HOUSING ASSEMBLY

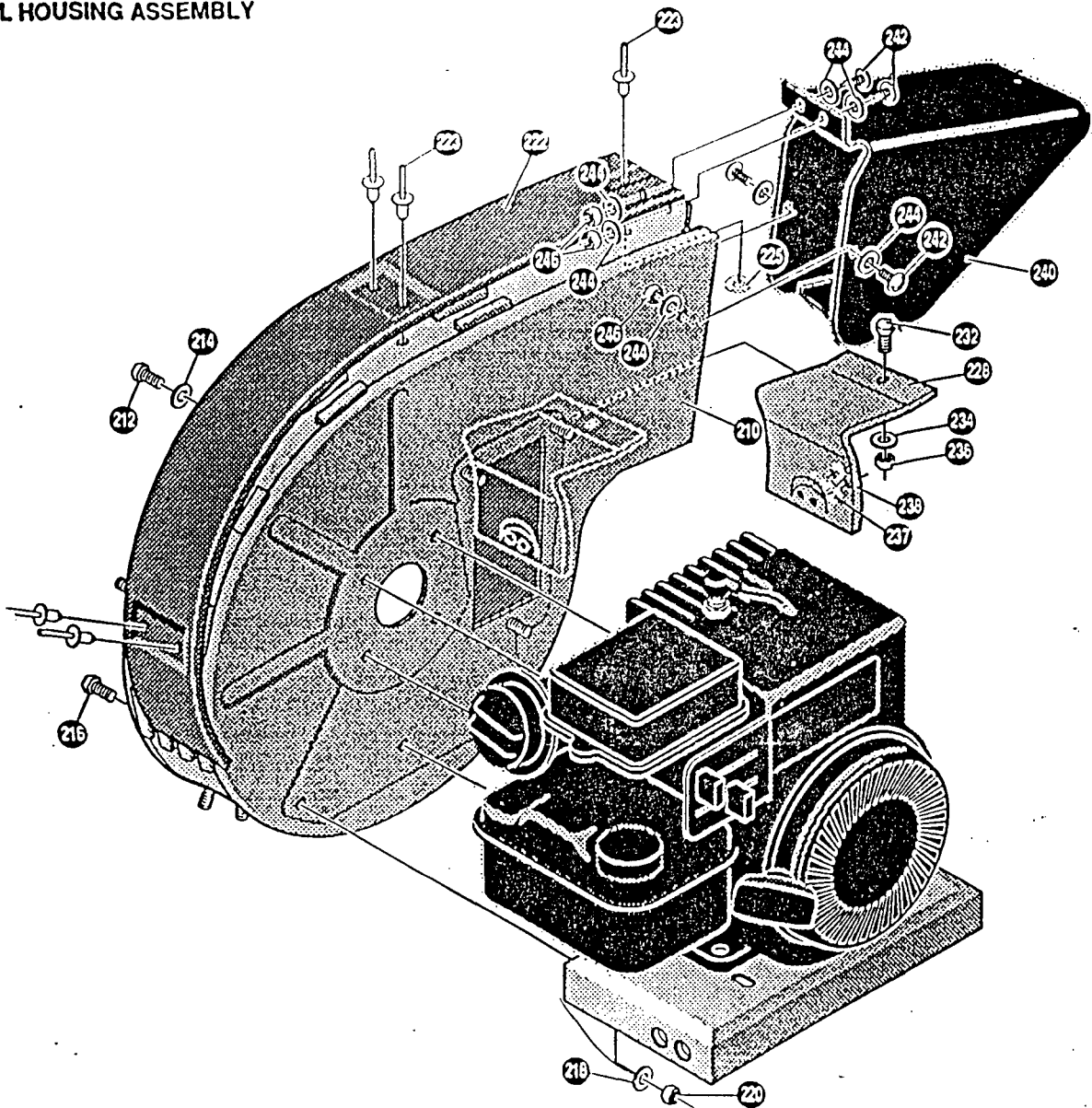

KEY #	PART #	DESCRIPTION
210	330108-889	FLAIL HOUSING, ASSEMBLY
212	181595	SCREW, 5/16-24 X .75
214	120638	WASHER, HVSP TLK .328 X .60 X .09
216	180077	SCREW, 5/16-18 X .75
218	996407	FLATWASHER, .328 X .75 X .077
220	1498	NUT, 5/16-18 REG HEX CTRLK
222	326833	SHROUD COVER, FLAIL
223		RIVET (NON SERVICEABLE)
225	1501	FLATWASHER, .203x.56x.040
228	330213-853	BAFFLE & STUDS ASSY.
232	180016	SCREW, 1/4-20X .50
234	120392	WASHER, FLAT .281X .63X .065
236	1502	NUT, 1/4-20 REG HEX CTRLK
237	996407	WASHER, FLAT .328 X .75 X .077
238	1498	NUT, 5/16-18 REG HEX CTRLK
240	330049-889	DEFLECTOR, ASSY (EXPORT)
242	330205	SCREW, 1/4-20X .50
244	120392	WASHER, FLAT .281X .63X .065
246	1502	NUT, 1/4-20 REG HEX CTRLK

NOTE: KEY 223, RIVET IS A NON-SERVICEABLE ITEM. ORDER 55686 SCREW, 1/4-20 X .63
 ALTSRMA, 57626 FLATWASHER, .281X1.25X.06, 51335 NUT 1/4-20 WDFL WHIZ-LK.

330210C-330211A

5 HP CHIPPER /SHREDDER PARTS D1705-100&130

CHIP CHUTE ASSEMBLY

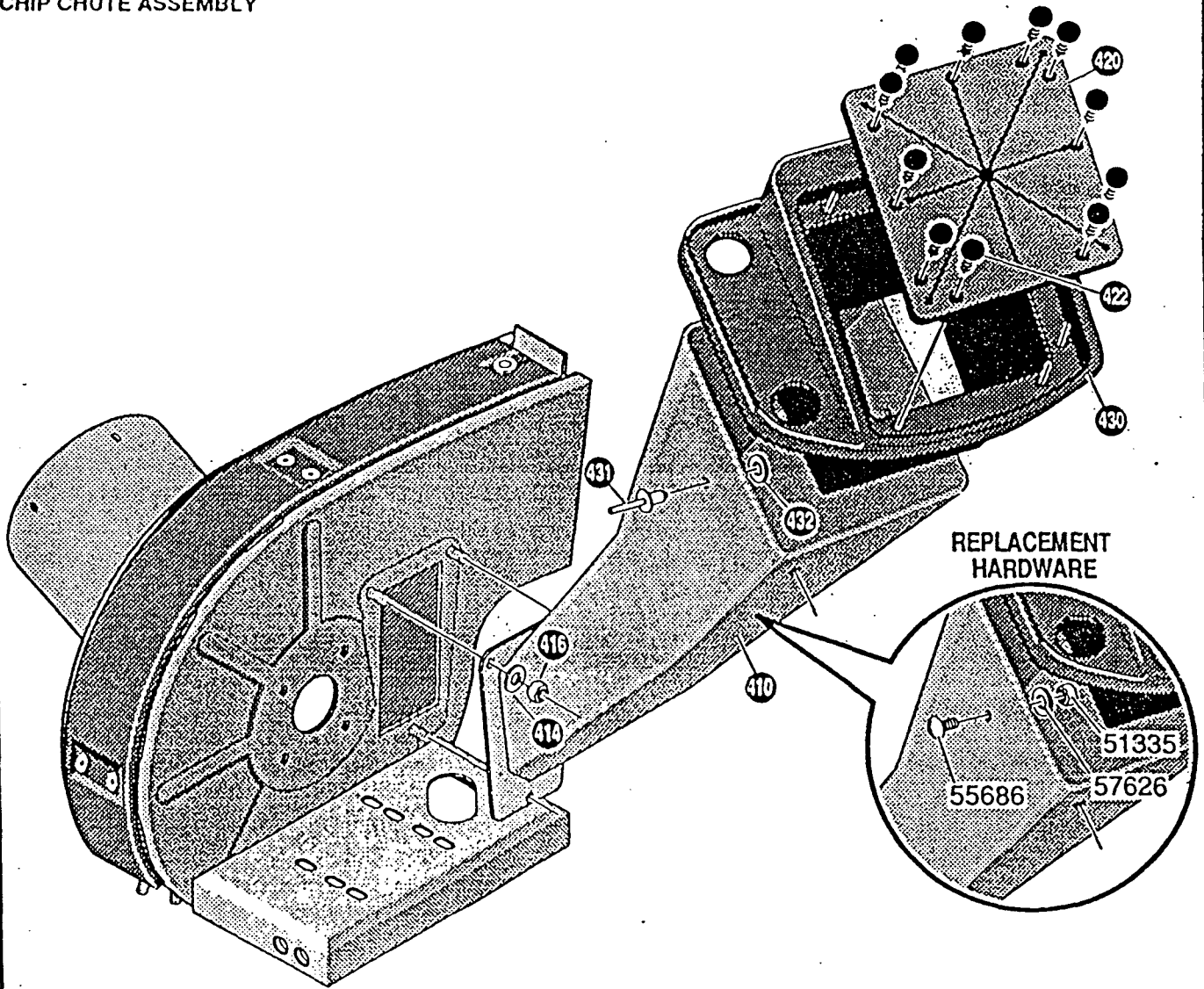

KEY #	PART#	DESCRIPTION
410	319863-889	CHUTE, ASSEMBLY CHIPPER
414	71071	WASHER, FLAT .349 X .69 X .066
416	71391	NUT, 5/16-18 REGHEXCTRLK
420	323333	GUARD, CHIPPER CHUTE
422	309235	FASTENER, RATCHET
430	326834	HOOD, CHIP CHUTE
431		RIVET, POP (NON SERVICEABLE) (SEE NOTE BELOW)
432	1501	WASHER, FLAT .203 X .56 X .040

325748C-328810B

NOTE: KEY 431, RIVET IS A NON-SERVICEABLE ITEM. ORDER 55686 SCREW, 1/4-20 X .63 SLTSRMA, 57626 FLATWASHER, .281X1.25X.06, 51335 NUT 1/4-20 WDFL WHIZ-LK AS SHOWN IN INSET TO REPLACE THE RIVET.

5 HP CHIPPER /SHREDDER PARTS D1705-100&130

JTE TUBE & PLATE ASSEMBLY

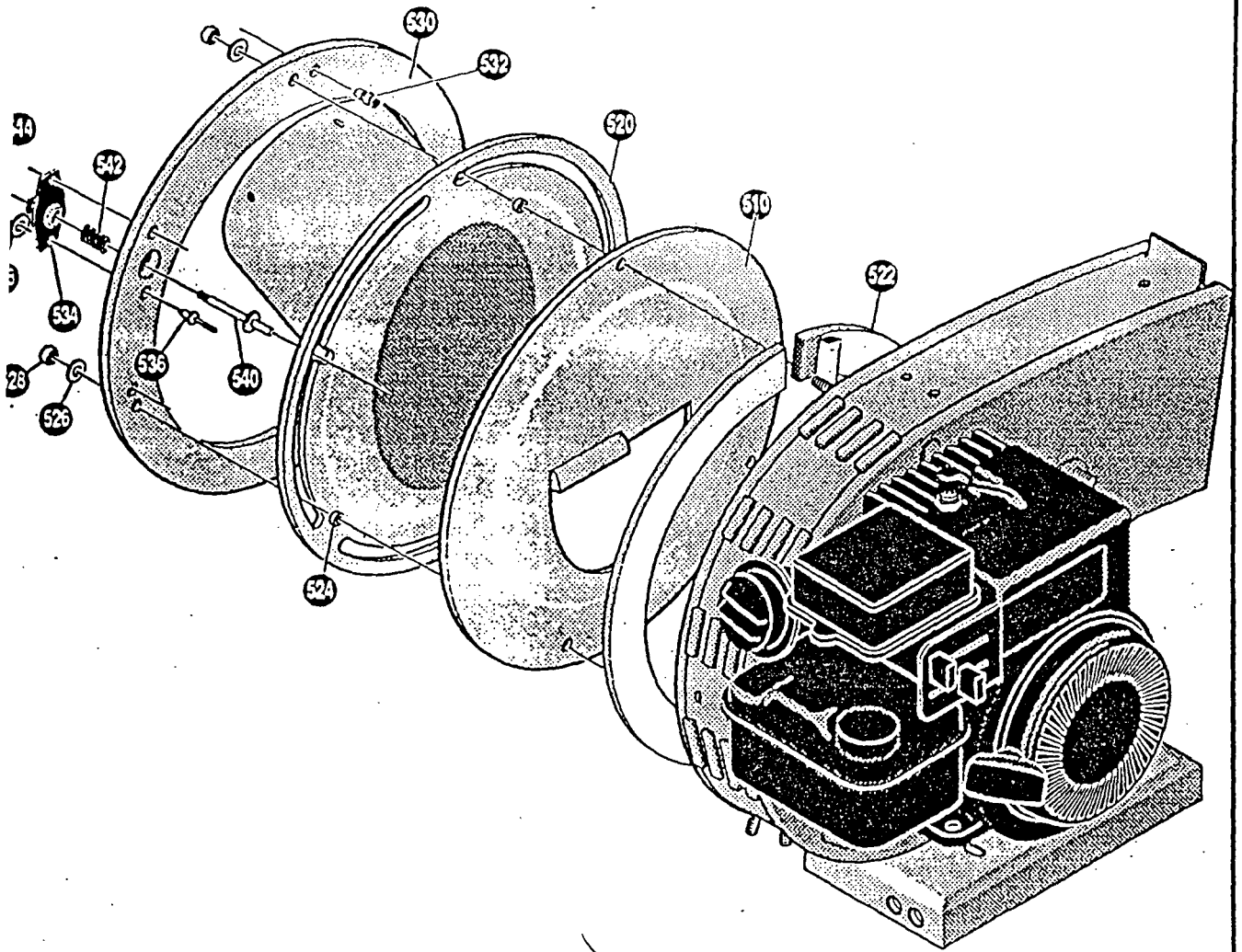

KEY #	PART#	DESCRIPTION
510	322864-889	PLATE, STATION ROTATE CHUTE
520	322777-889	TUBE & PLATE, ASSEMBLY CHUTE
522	323338	SEAL, SHREDDER CHUTE
524	322738	BUSHING, ROTATE CHUTE
526	313677	WASHER, FLAT .391 X 1.00 X .125
528	71111	NUT, 3/8-16 REGHCTRLK
530	322776-889	RETAINER COVER
532	324197	FITTING, LUB-PRESS FIT
534	323932	RETAINER, SPRING
536	46763	RIVET, POP .187DIA X .450LG
538	414106	FLATWASHER, .188X.38X.040
540	322741	RELEASE, HANDLE
542	322739	SPRING, COMPRESSION
544	325083	KNOB, .75 DIA.

325749B-328819B

5 HP CHIPPER /SHREDDER PARTS D1705-100&130

DECALS

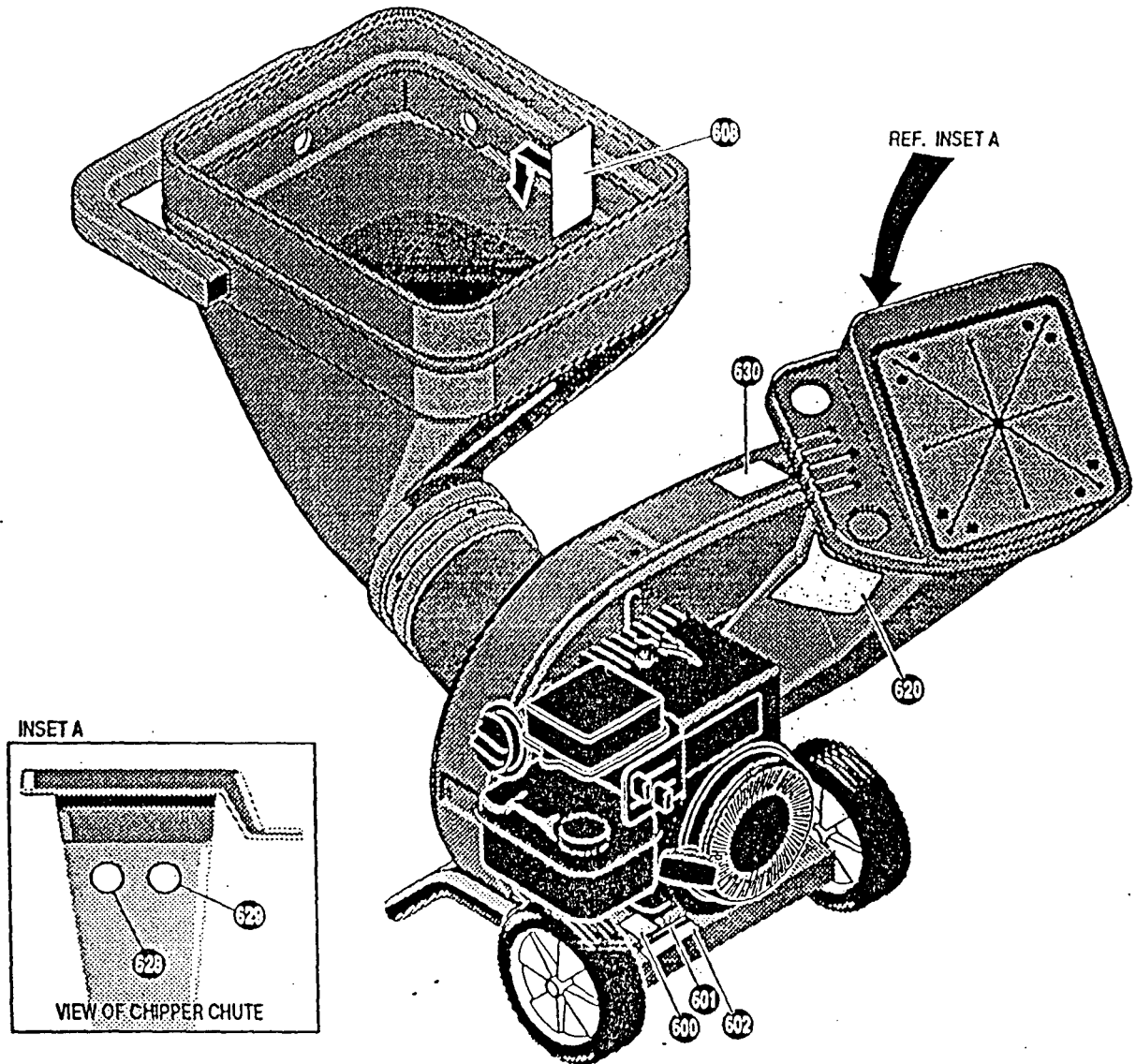

KEY #	PART#	DESCRIPTION
600		REFERENCE ONLY
601		REFERENCE ONLY
602		REFERENCE ONLY
608	330176	DECAL, EXPORT, CAUTION GER
608	330450	DECAL, EXPORT, CAUTION ENG/FR
620	330451	DECAL, OPERATOR ENG/FR
620	330177	DECAL, OPERATOR GER
628	402261	DECAL, HEARING PROTECTION
629	402260	DECAL, EYE PROTECTION
630	330178	DECAL, EXPORT, DANGER GER
630	330452	DECAL, EXPORT, DANGER ENG/FR

330802A-328831D

5 HP CHIPPER /SHREDDER PARTS D1705-100&130

TOOLS ASSEMBLY

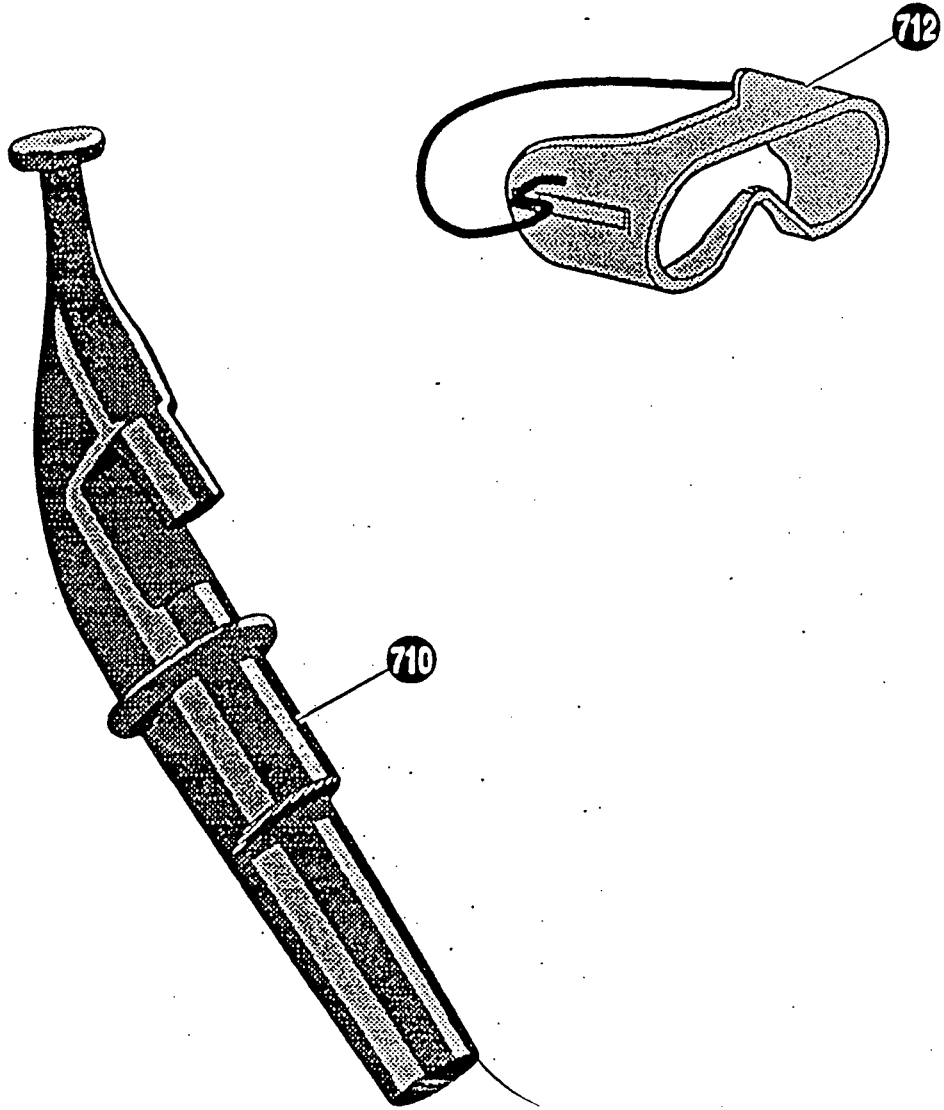

KEY #	PART #	DESCRIPTION
710	327243	TAMPER, CHIP/SHRED
712	327789	GOGGLES, VENTED

326090B-328244A

5 HP CHIPPER /SHREDDER PARTS D1705-100&130

BAG COLLECTOR ASSEMBLY

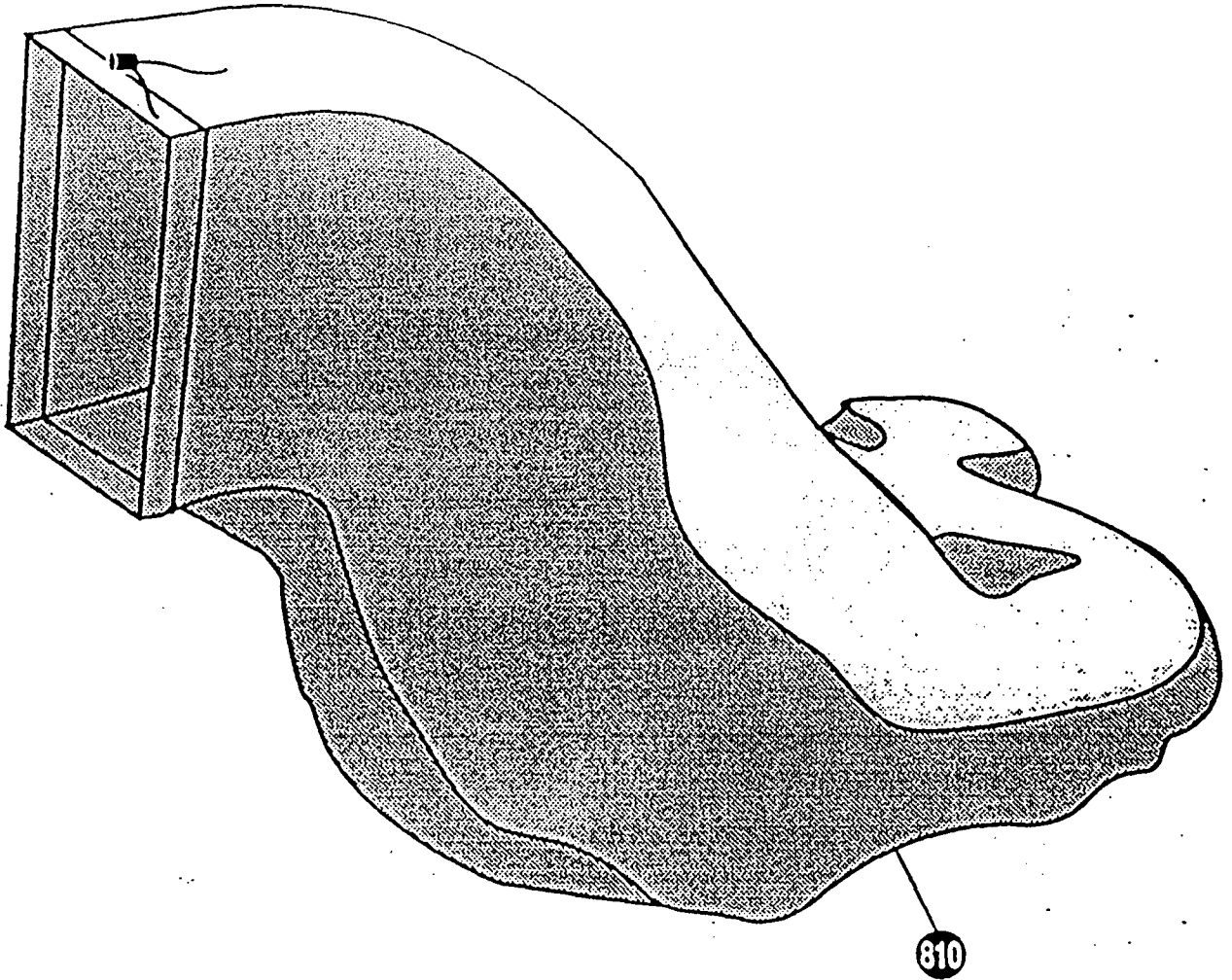

KEY #	PART #	DESCRIPTION
810	320376	BAG, COLLECTOR, DRAWSTRING

326091A-328248B

CHIPPER/SHREDDER ACCESSORIES

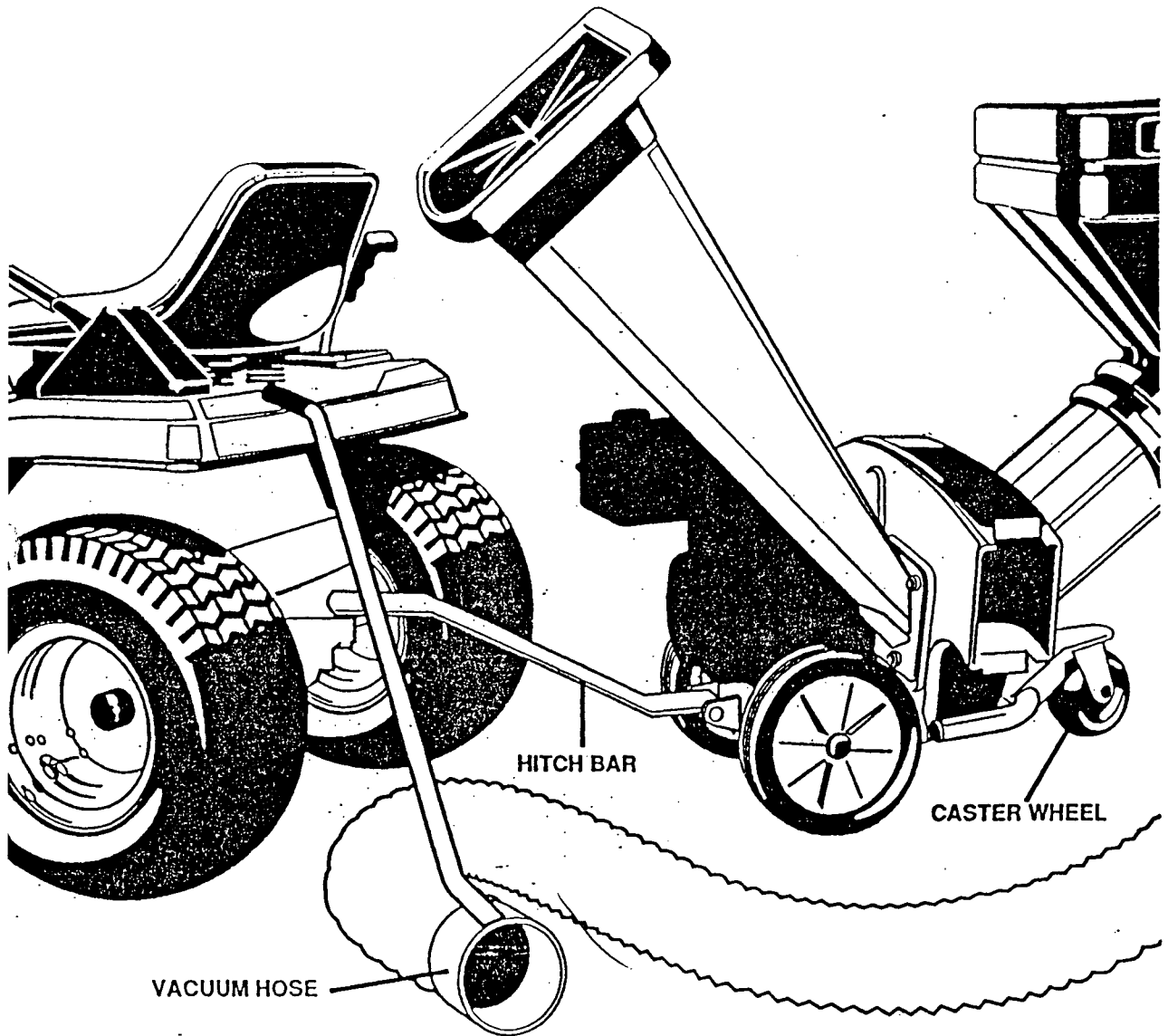

Following pages illustrate optional equipment that can be added to your Chipper/Shredder. If your unit is already equipped with these items, use the information to order service parts.

5800-00 VACUUM HOSE KIT

10 foot hose will easily vacuum leaves and debris in hard to reach places.

5800-01 HITCH BAR KIT

To tow the Chipper/Shredder behind your tractor. For units equipped w/caster wheels.

5800-02 CASTER WHEEL KIT

For added maneuverability.

5800-03 TOWING KIT

Complete kit to tow Chipper/Shredder behind your tractor.

MODEL 5800-0000 VACUUM HOSE ATTACHMENT KIT

THIS KIT INCLUDES THE FOLLOWING:

Your vacuum hose attachment comes completely assembled and ready to use with your Chipper/Shredder.

TOOLS REQUIRED FOR ASSEMBLY:

- 1 - Wire Cutters (or knife)

TO INSTALL VACUUM HOSE:

- Remove hose attachment from carton and remove the (2) straps holding the handle to the tube.
- Lay the hose attachment out straight on the ground to remove any twist in the hose.
- With the engine stopped, insert the hose attachment adapter (#730) into the hopper assembly tube (See Fig. 1) and turn approximately 1/6 of a turn counterclockwise until the adapter locks in place.
- The hose attachment can be used with the hopper assembly in the "up" position but performance is increased by rotating the hopper assembly to the ground.
- The vacuum hose attachment works best when used on dry leaves, grass, etc. If the material is too wet, or if a large twig, etc. enters the hose, clogging may occur. If your vacuum hose becomes clogged, stop the engine, remove the adaptor from the hopper assembly, hold the hose in a vertical position and shake the hose - until the hose is clear.
- Periodically, after use, flush the inside of the hose with water using standard garden hose.

Service Parts: (See Fig. 2)

Key#	Part#	Description
730	324712	Adapter Hose Attachment
732	39909	Clamp Hose
734	41629-853	Handle
736	328178	Grip, Handle
738	271172	Nut, 1/4-20 REGHEXKEPS
744	41631	Clamp, Intake
746	41632	Clamp, Intake
748	36602	Bolt, 1/4-20x.63 CARR.
749	120385	Washer, Flat .312x.73x
750	48261	Tube, Flex

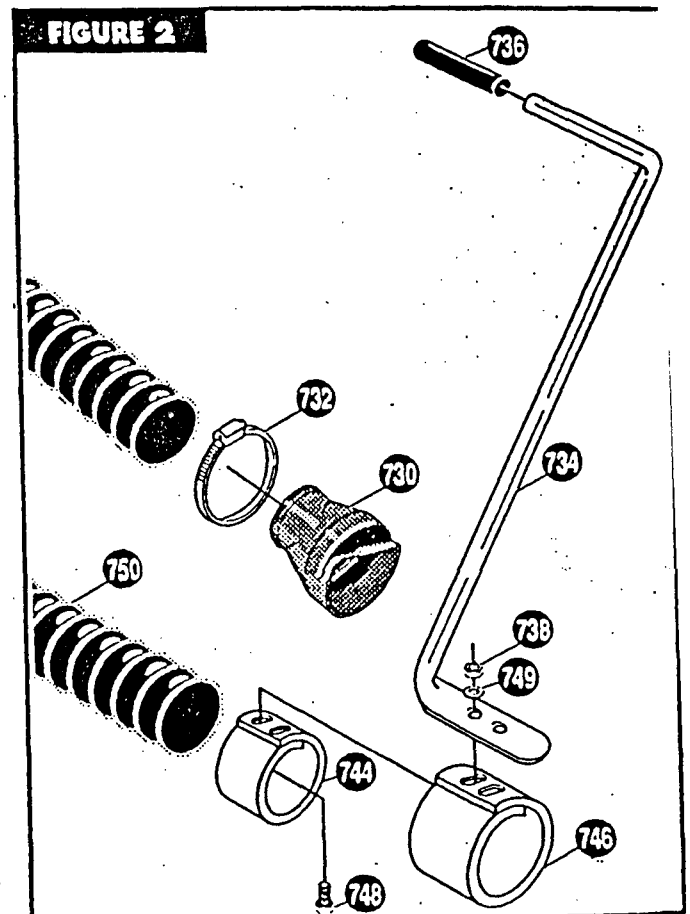
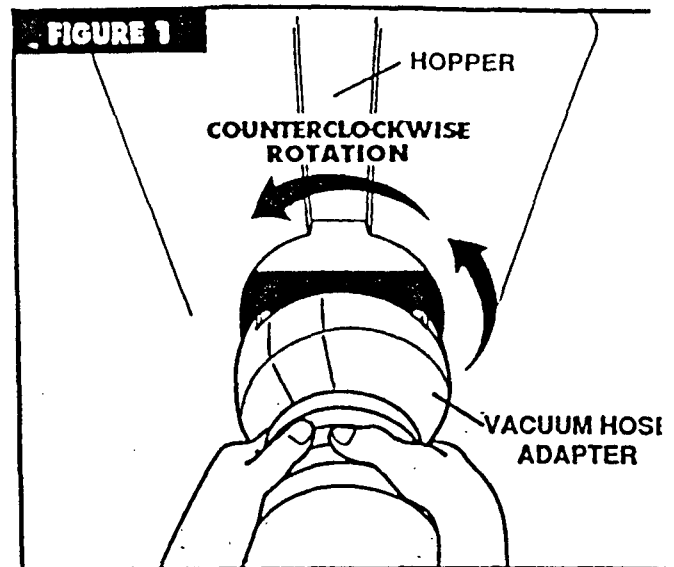

5800-0100 HITCH BAR KIT

NOTE:

Hitch bar kit must be used with castor wheel kit (See separate instruction sheet supplied with castor wheel for castor wheel installation).

Remove draw bar kit pivot bracket (#857), tongue (#862) and its bag from the carton.

TOOLS REQUIRED FOR ASSEMBLY:

1/2 inch wrench (or adjustable wrench)

HOW TO INSTALL HITCH KIT:



WARNING: To reduce the potential for any injury, comply with the safety instructions found in your tractor and chipper/shredder owner's manual.

Locate hitch bar kit pivot bracket (#857). (NOTE: If your model of Chipper/Shredder was equipped from the factory with a hitch, the pivot bracket is already attached to your unit).

- Position pivot bracket as shown in Fig. 1, aligning (2) holes in pivot bracket with (2) holes in front of the engine plate.
- Attach pivot bracket to engine plate using the 5/16-18x.75 inch screws (#858), .312x.73 flat washers (#859), and 5/16-18 hex locknuts (#860). Tighten locknuts securely.
- Position tongue (#862) with pin facing downward and away from unit as shown in Fig. 1.
- Attach tongue to pivot bracket using clevis pin (#863), flat washers (#864) and hair pin (#865) (See FIG. 1).
- Install clevis pin (#867) and hair pin (#868) into desired hole position (See FIG. 1). Position #1 is used when towing the Chipper/Shredder. Position #2 is used to support the tongue, when not towing, for normal operation.
- Place pin in tongue through hitch on back of tractor and secure using flatwasher (#870) and hair pin (#871).

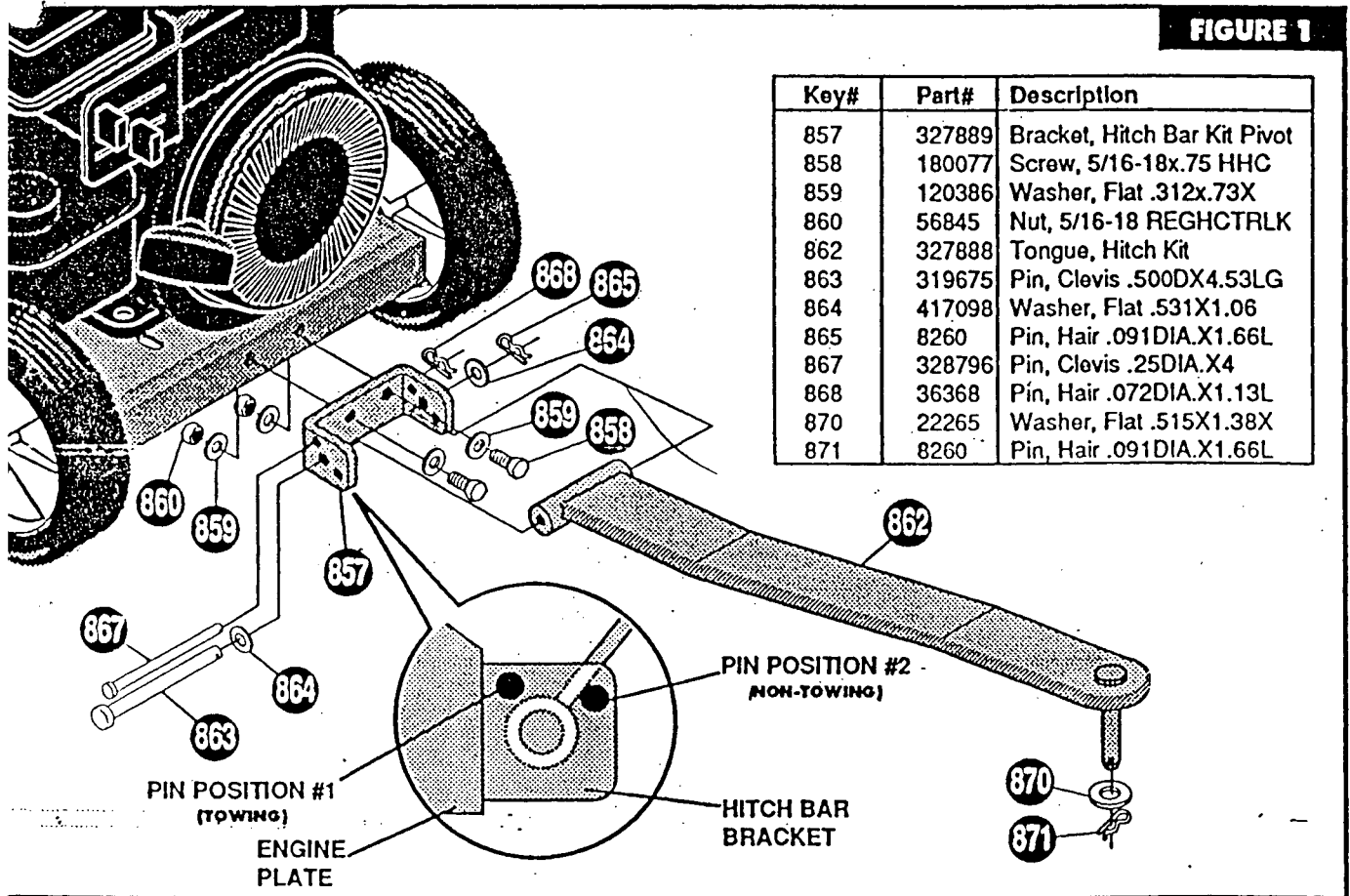

5800-0200 CASTER WHEEL KIT

THIS KIT INCLUDES THE FOLLOWING:

Your caster wheel kit comes completely assembled and ready to attach to your Chipper/Shredder.

TOOLS REQUIRED FOR ASSEMBLY:

1 - 1/2" Wrench

TO INSTALL CASTER WHEEL:



WARNING: TO REDUCE THE POTENTIAL FOR ANY INJURY, COMPLY WITH THE SAFETY INSTRUCTIONS FOUND IN YOUR CHIPPER/SHREDDER OWNER'S MANUAL. INSTALLATION OF ATTACHMENTS SHOULD BE DONE ONLY WHEN ENGINE IS STOPPED.

- REMOVE CASTER WHEEL ASSEMBLY AND PARTS BAG FROM CARTON
- With Chipper/Shredder on a level surface, carefully tilt the unit forward to access the leg support.
- Using a 1/2" wrench, remove four 5/16-18 locknuts (Item C), spring washers (Item B), and one existing leg support (Item A) from the unit. (See Figure 1)
- Align the four slots in the caster wheel with the four threaded studs on the Chipper/Shredder housing.
- Attach the caster wheel assembly (Item A) using the spring washers (Item C) and 5/16-18 hex locknuts (Item B). Do not tighten. (See Figure 2)
- Visually align the caster wheel frame horizontally.
- Tighten locknuts securely.
- Carefully lower Chipper/Shredder to operating position.

Service Parts: (See Fig. 3)

Key#	Part#	Description
820	327153	Caster Wheel Support Frame
822	25840	Washer, Spring
824	56845	Nut, 5/16-18 REGHCTRLK
828	327106	Plug, Tube
830	327156	Caster Wheel Yoke
831	325892	Washer, Plastic .06X.625X1.5
832	706	Zerk, Grease Fitting
833	40677	Washer, Flat .640X1.25X.06
834	53806	Washer, Flat .632X.11X.061
836	326863	Spacer, Sleeve .640X1.00X.688
838	302270	Ring, Retex .58X.05
840	327874	Wheel, Caster LH
842	327875	Wheel, Caster RH
844	327157	Pin, Caster Wheel Axle
845	120396	Washer, Flat .531X1.06X.095
846	328713	Spacer, Sleeve .515X1.00X.852
848	996416	Washer, Flat .391X1.00X.125
850	1499	Nut, 3/8-16 REGHCTRLK

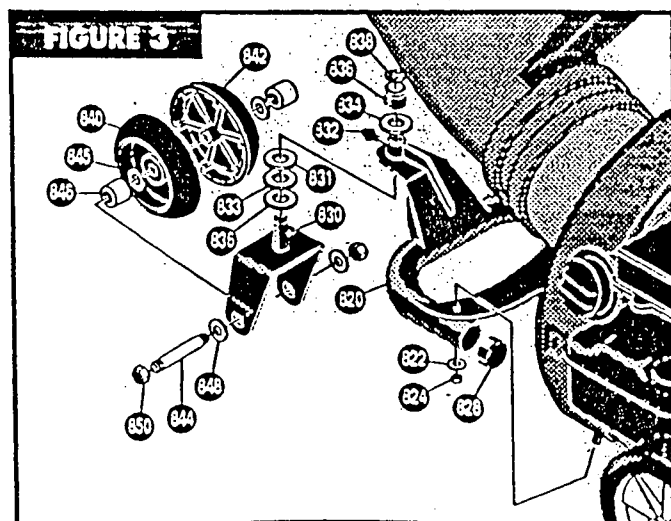
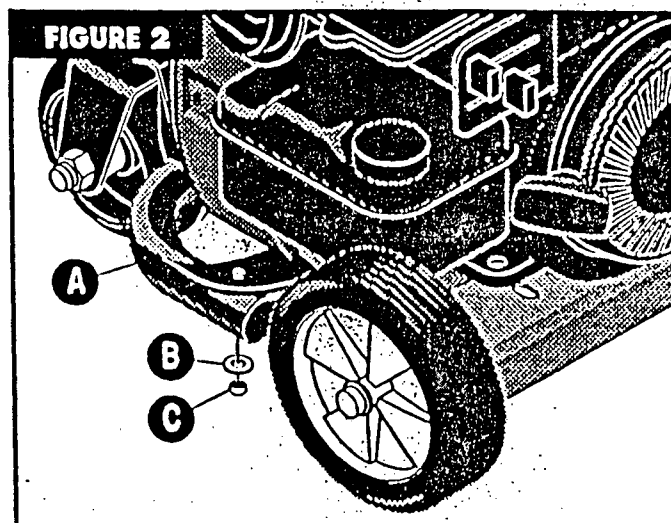
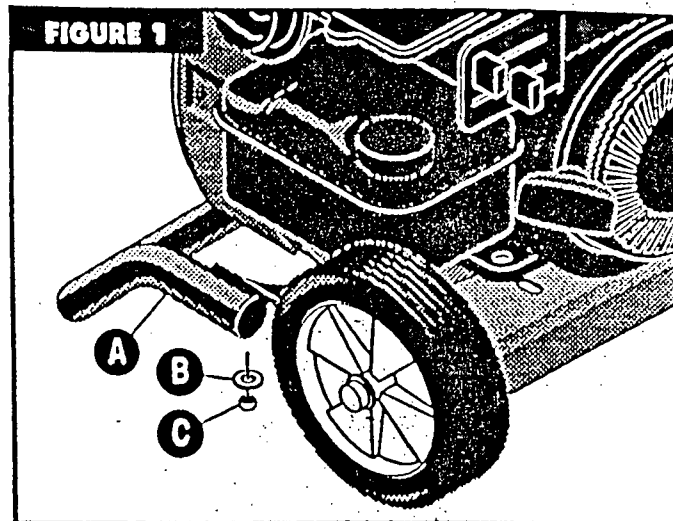

5800-0300 TOWING KIT

TOOLS REQUIRED FOR ASSEMBLY:

Wrench

INSTALL TOWING KIT:

WARNING: To reduce the potential for any injury, comply with the safety instructions found in your tractor and chipper/shredder owner's manual.

Locate hitch bar kit pivot bracket (#857). (NOTE: If your model of Chipper/Shredder was equipped from the factory with a hitch, the pivot bracket is already attached to your unit).

Position pivot bracket as shown in Fig. 1, aligning (2) holes in pivot bracket with (2) holes in front of the engine plate.

Attach pivot bracket to engine plate using the 5/16-18 x .75 inch screws (#858), .31x.73 flatwashers (#859), and 5/16-18 hex locknuts (#860). Tighten locknuts securely.

Position tongue (#862) with pin facing downward and away from unit as shown in Fig. 1.

Attach tongue to pivot bracket using clevis pin (#863), flatwashers (#864) and hair pin (#865) (See Fig. 1).

- Install clevis pin (#863) and hair pin (#865) into desired hole position (See Fig. 1). Position #1 is used when towing the Chipper/Shredder. Position #2 is used to support the tongue, when not towing, for normal operation.
- Place pin in tongue through hitch on back of tractor and secure using flatwasher (#870) and hair pin (#871).

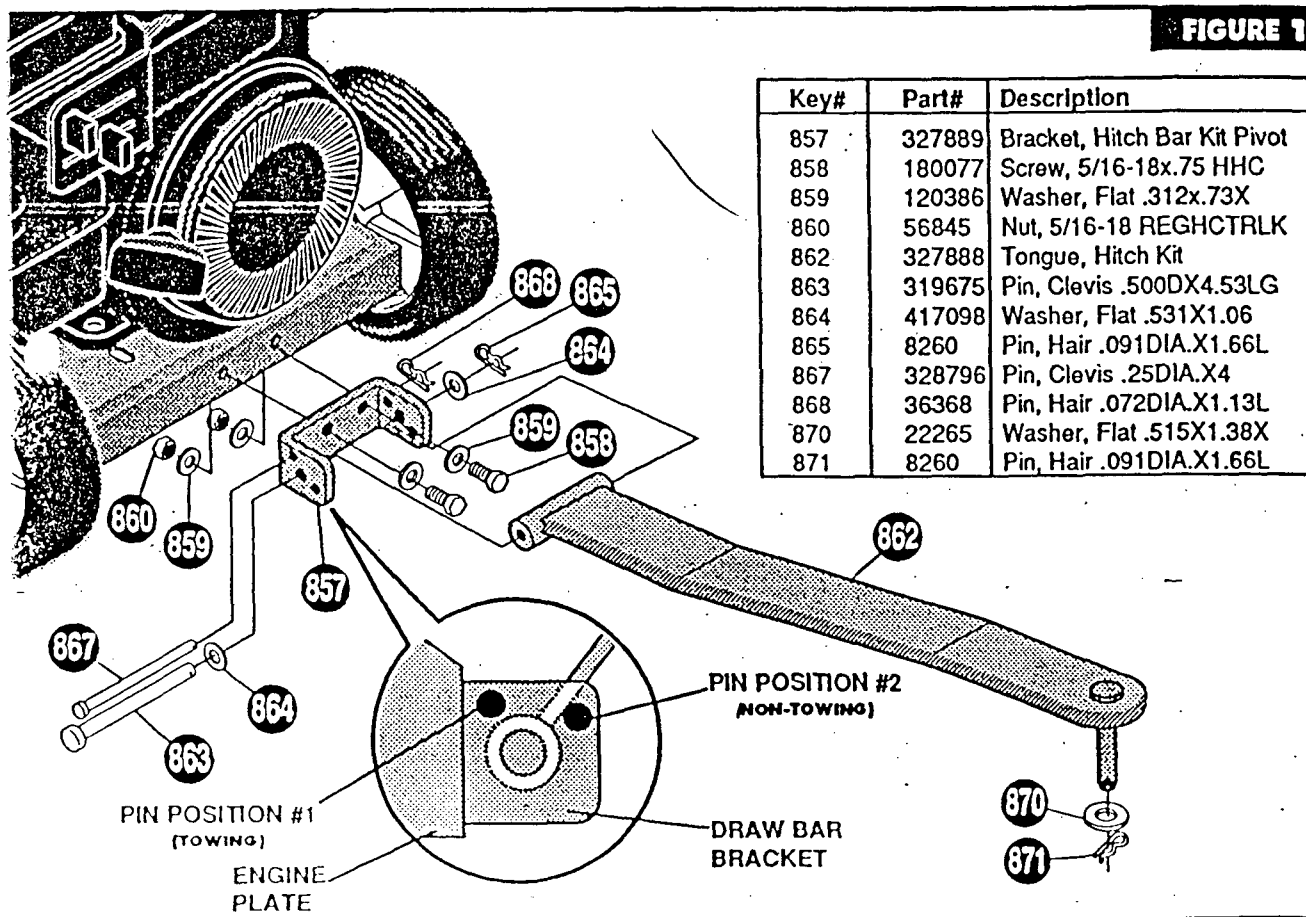

FIGURE 1

5800-0300 TOWING KIT

TO INSTALL CASTER WHEEL:



WARNING: TO REDUCE THE POTENTIAL FOR ANY INJURY, COMPLY WITH THE SAFETY INSTRUCTIONS FOUND IN YOUR CHIPPER/SHREDDER OWNER'S MANUAL. INSTALLATION OF ATTACHMENTS SHOULD BE DONE ONLY WHEN ENGINE IS STOPPED.

- REMOVE CASTER WHEEL ASSEMBLY AND PARTS BAG FROM CARTON
- With Chipper/Shredder on a level surface, carefully tilt the unit forward to access the leg support.
- Using a 1/2" wrench, remove four 5/16-18 locknuts (Item C), spring washers (Item B), and one existing leg support (Item A) from the unit. (See Figure 2)
- Align the four slots in the caster wheel with the four threaded studs on the Chipper/Shredder housing.
- Attach the caster wheel assembly (Item A) using the spring washers (Item C) and 5/16-18 hex locknuts (Item B). Do not tighten. (See Figure 3)
- Visually align the caster wheel frame horizontally.
- Tighten locknuts securely.
- Carefully lower Chipper/Shredder to operating position.

Service Parts: (See Fig. 4)

Key#	Part#	Description
820	327153	Caster Wheel Support Frame
822	25840	Washer, Spring
824	56845	Nut, 5/16-18 REGHCTRLK
828	327106	Plug, Tube
830	327156	Caster Wheel Yoke
831	325892	Washer, Plastic .06X.625X1.5
832	706	Zerk, Grease Fitting
833	40677	Washer, Flat .640X1.25X.06
834	53806	Washer, Flat .632X.11X.061
836	326863	Spacer, Sleeve .640X1.00X.688
838	302270	Ring, Retex .58X.05
840	327874	Wheel, Caster LH
842	327875	Wheel, Caster RH
844	327157	Pin, Caster Wheel Axle
845	120396	Washer, Flat .531X1.06X.095
846	328713	Spacer, Sleeve .515X1.00X.852
848	996416	Washer, Flat .391X1.00X.125
850	1499	Nut, 3/8-16 REGHCTRLK

