

ILLUSTRATED PARTS LIST

MODEL NAMES	SERIAL NUMBER PREFIX	MODELS
MAC 2818	12-	400128-02
EAGER BEAVER 287	12-	400128-10
EAGER BEAVER 287	12-	400128-30
EAGER BEAVER 287	12-	400128-48
EAGER BEAVER 287	12-	400128-52
SILVER EAGLE 28C	12-	400128-06
SILVER EAGLE 28C	12-	400128-20
SILVER EAGLE 28C	12-	400128-50

McCulloch products are identified by a model number (in this instance 400128) followed by a suffix number (02 or 03). Suffix numbers denote variations in parts or assemblies used in the manufacture of this product.

Illustrated Parts Lists (IPLs) contain a PART NUMBER, DESCRIPTION, UNITS per assembly and STOCKING CODE for each part. Stocking Codes are:

- A - Dealer stocked. Fast to medium moving part
- B - Distributor stocked. Medium to slow moving part.
- C - Factory stocked. Slow moving part
- T - Indicates a McCulloch service tool.

NOTE: The following explains symbols/footnotes in this IPL.

(-) A dash preceding a PART NUMBER indicates that it is a new part number, different from the one listed in the previous IPL for this unit.

(.) One or more dots (. Spring-Starter) preceding a part DESCRIPTION indicates the part is included in the kit or assembly described directly above the dot(s).

(---) If four dashes appear in place of a PART NUMBER, the part is not available individually but is included in the next higher assembly or subassembly.

① ② Circled numbers preceding a DESCRIPTION footnote the part or assembly to additional information on the page.

(*) An asterisk draws attention to general information.

The policy of McCulloch Corporation is one of continual improvement in design, manufacturing and engineering advancement wherever possible to assure still finer power tools. Hence, specifications, equipment, colors, design and manufacturer's suggested list prices are subject to change without notice. McCulloch Corporation reserves the right to make such changes without prior notification or obligation to backfit or supply backfit components for units previously shipped from the factory.

MARCH 1993

MAC
EAGER BEAVER
SILVER EAGLE

28CC
GAS-POWERED
STRING TRIMMERS



CONTENTS

	PAGE
FIGURE 1 Powerhead Assembly	2
FIGURE 2 Starter Housing Assembly	4
FIGURE 3 Carburetor Assembly	5
FIGURE 4 Shaft, Handle and Cutter Assemblies	6
Specifications and Service Tools	7

McCULLOCH®

P.O. Box 11990 • Tucson, Arizona 85734

P/N 211321

FIGURE 1 POWERHEAD ASSEMBLY

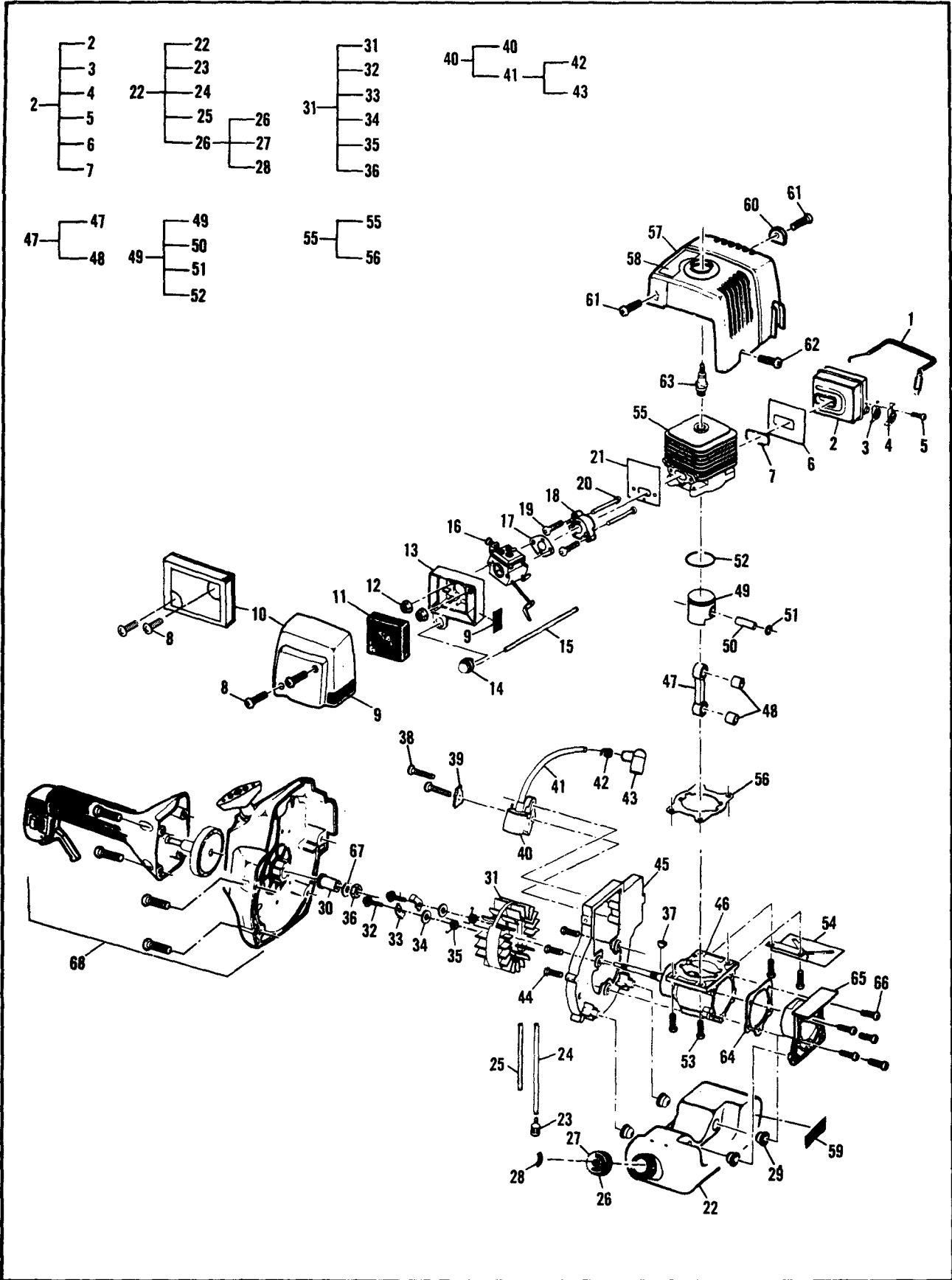

FIGURE 1

POWERHEAD ASSEMBLY

ITEM NO.	STK. CODE	PART NUMBER	DESCRIPTION	UNITS PER ASY.
1	B	224044	Spring, Muffler	1
2	A	300628	Kit, Muffler	1
3	B	224040	. Screen, Spark Arrester	1
4	B	322032	. Cover, Spark Arrester	1
5	B	111072	. Screw, 8-18 x .31 PN HD TORX	1
6	B	224228	. Gasket, Muffler	1
7	B	224922	. Gasket, Exhaust Port	1
8	A	111055	Screw, 10-14 x .625 Plastite	2
9	B	322477	① Label, Choke(Vertical)	1
	B	322478	② Label, Choke(Horizontal)	1
	A	322240	③ Label, Choke	1
10	C	224237	Cover, Air Cleaner-Small (Blk)	1
	B	224236	② Cover, Air Cleaner-Large(Blk)	1
11	A	224239	Filter, Air	1
12	A	111058	Nut, 10-24 Flange / Hex	2
13	B	224238	Box, Air (Blk)	1
14	A	224242-01	Primer, Remote	1
15	A	225163	Hose, Fuel Return	1
16		FIGURE 3	CARBURETOR W/CHOKE	1
17	A	218933	Gasket, Carburetor	1
18	B	224041	Manifold, Carburetor	1
19	B	111053	Screw, 10-24 x .88	2
20	A	111057	Screw, 10-24 SPL	2
21	A	322031	Gasket, Manifold	1
22	B	300871	Kit, Fuel Tank / Cap (Blk)	1
23	A	216985	. Pickup, Fuel	1
24	A	225162	. Hose, Fuel	1
25	A	225163	. Hose, Fuel Return	1
26	A	300700	. Kit, Fuel Cap/Decal	1
27	C	211242	.. Decal, (OPEN SLOWLY)	1
28	C	322250	.. Decal, Fuel Cap	1
29	A	322105	Isolator, Fuel Tank	4
30	C	322842	Spacer, Clutch	1
31	B	300827	Kit, Flywheel	1
32	B	111090	. Screw, Starter Pawl 12-24 L.H.	2
33	B	322320	. Pawl, Starter	2
34	B	93469	. Washer, Starter Pawl	2
35	B	223339	. Spring, Starter Pawl	2
36	C	111085	. Nut	1
37	A	102164	Key, Flywheel	1

ITEM NO.	STK. CODE	PART NUMBER	DESCRIPTION	UNITS PER ASY.
38	B	111053	Screw, 10-24 x .88 THD Form	2
39	B	300321	Terminal Tab	1
40	A	219848-01	Ignition Assembly	1
41	A	223884	. Kit, Spark Plug Wire	1
42	B	102556	.. Connector, Spark	1
43	B	95266	.. Boot, Spark Plug	1
		----	.. Grommet, H/T Lead	1
		----	.. Grommet, S/Plug Wire	1
44	B	111054	Screw, 10-24 x .625	3
45	B	224042	Shroud, Engine Machined	1
46	C	300766	Crankcase / Shaft Assembly CD	1
		----	. Crankshaft Assembly	1
		----	. Crankcase, Machined	1
		----	.. Bearing 6202	1
		----	.. Bearing 6202RS	1
		----	.. Seal	1
		----	.. Spacer	1
		----	.. O Ring	1
47	B	224009	Connecting Rod Assembly	1
48	A	91117	. Bearing	2
49	C	300661	Kit, Piston, 28cc Aluminum	1
50	B	300482	. Piston Pin, C'shaft (10mm dia)	1
51	B	215876	. Ring, Retaining	1
52	B	224224	. Ring, Piston 35mm	1
53	B	111065	Screw, 10-24 x .688 Tri Rnd	4
54	B	322030	Shield, Muffler	1
55	B	300452	Kit, Cylinder 28cc Chrome	1
56	B	224022	. Gasket, Cylinder	1
57	B	224235	Cover, Cylinder/Muffler (Blk)	1
58	B	322480	Label, Start Instructions (SLI/SW)	1
59	C	322100	Label, Storage	1
60	B	322210	Washer, Plastic	1
61	B	111067	Screw, 10-24 x .63 SL TORX TP	2
62	B	111068	Screw, 10-14 x 1.38 Taptite	1
63	A	62345	Spark Plug / DJ8J	1
	A	92879	③ Spark Plug / RDJ8J	1
64	B	224023	Gasket, Crankcase	1
65	B	224024	Plug, Crankcase	1
66	B	111065	Screw, 10-24 x .688 Tri Rnd	5
67	C	322844	Washer	1
68		FIGURE 2	STARTER HOUSING ASSEMBLY	

- ① 12400128-02
12400128-10
12400128-30
12400128-48
- ② 12400128-06
12400128-20
12400128-50
- ③ 12400128-52

FIGURE 2 STARTER HOUSING ASSEMBLY

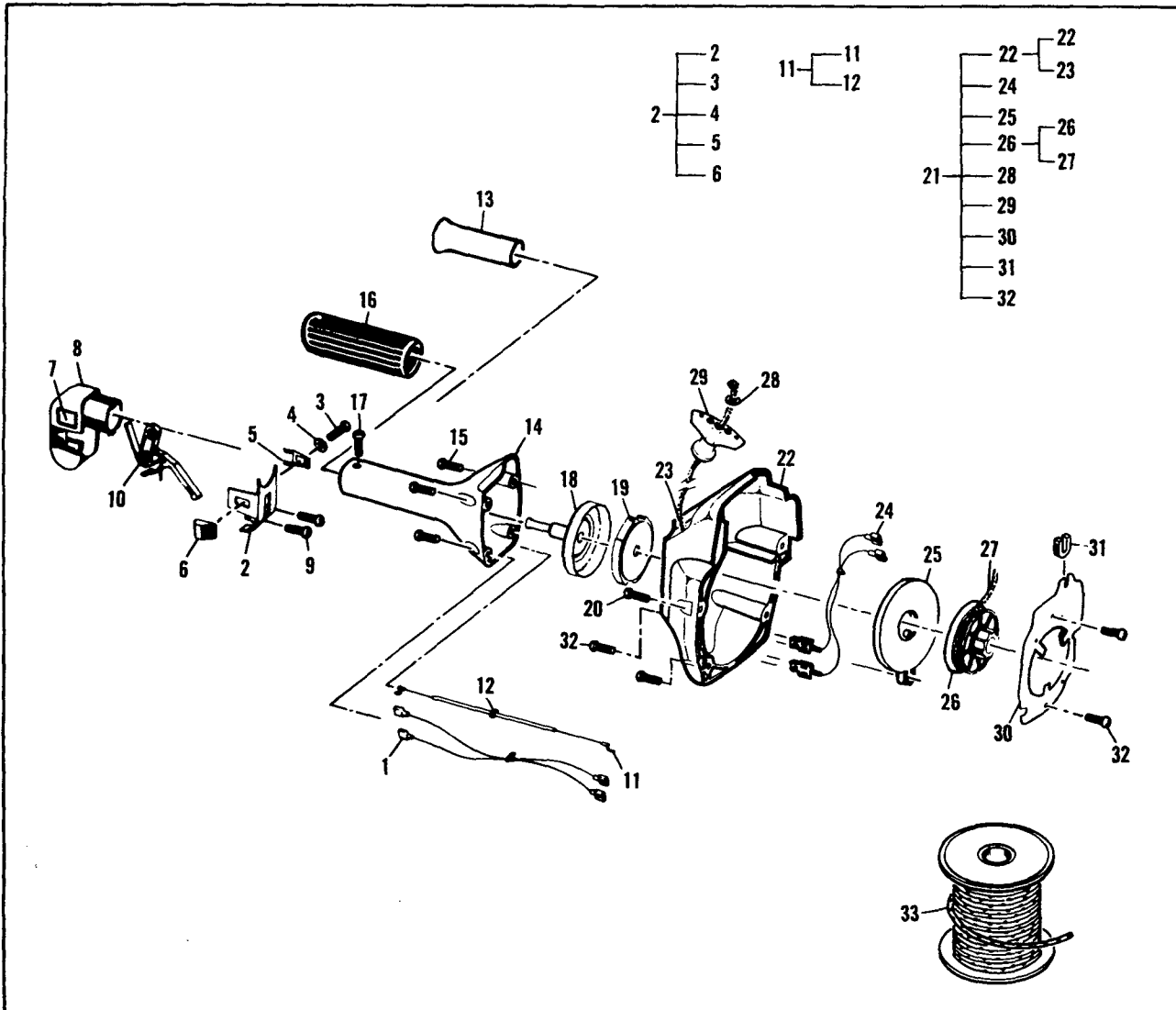

ITEM NO.	STK. CODE	PART NUMBER	DESCRIPTION	UNITS PER ASY.	ITEM NO.	STK. CODE	PART NUMBER	DESCRIPTION	UNITS PER ASY.
1	B	224204	Wire Assembly, Switch	1	18	B	224045	Drum Assembly, Clutch	1
2	B	300064	Cover Assembly, Switch	1	19	B	300459	Kit, Clutch	1
3	B	111069	Screw, 8-16 x .375 Plastite	1	20	B	111054	Screw, 10-24 x .625	4
4	B	105497	Washer, Flat (.180 ID max)	1	21	B	224916	① Starter Housing Asy. (Yellow)	1
5	B	224246	Contact, Switch	1	22	B	300616	Housing/Guide, Rope (Yellow)	1
6	B	224245	Button, Stop Switch	1		B	300013	② Starter Housing Asy. (Grey)	1
7	B	322081	Label, ON/OFF Switch	1		B	300618	Housing/Guide, Rope (Grey)	1
8	B	224234	Trigger Housing Assembly 22mm	1	23		---	Guide, Rope	1
9	B	111061	Screw, 6-19 x .62 FL HD Plast	2	24	B	300369	Wire Assembly	1
10	B	300361	Trigger, Throttle	1	25	A	300475	Package, Spring Assembly	1
11	B	300372	Throttle Cable Assembly	1	26	A	300872	Drum/Rope Assembly	1
12	B	111074	Nut, Speed .188 ID	1	27	A	222869	Rope, Starter (46")	1
13	B	322234	Sleeve, Protecting	1	28	A	218941	Washer, Nylon	1
14	B	224912	① Housing, Clutch (Yellow) 7/8"	1	29	A	216792	Handle, Starter	1
	B	300014	② Housing, Clutch (Grey) 7/8"	1	30	B	224927	Plate, Baffle	1
15	B	224919	Screw, 10-14 x 1.0 PN HD	4	31	B	215533-01	Grommet, H/T Lead	1
16	B	322140	Grip	1	32	B	223357	Screw, 8-16 Plastite	3
17	B	111070	Screw, 12-11 x .5 PN HD TORX	1	33	B	300415	Rope, Bulk	1

- ① 12400128-02 ② 12400128-06
- 12400128-10 12400128-20
- 12400128-30 12400128-50
- 12400128-48
- 12400128-52

FIGURE 3 CARBURETOR ASSEMBLY

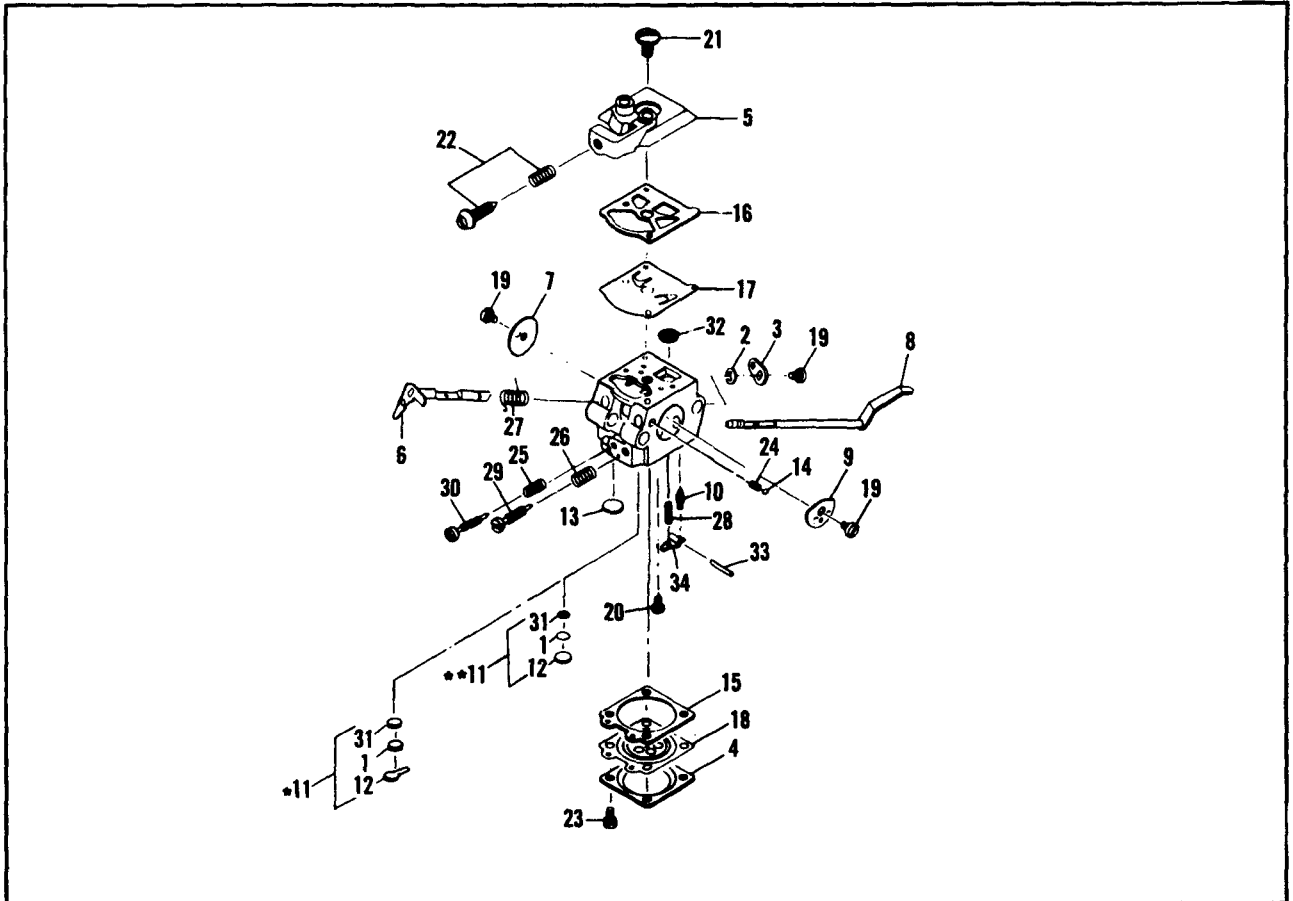

ITEM NO.	STK CODE	PART NUMBER	DESCRIPTION	UNITS PER ASY.
	B	224033-02	Carburetor w/Choke, Walbro WT-231A**	
	A	224033-01	Carburetor w/Choke, Zama M29*	
1		①④	Ring, Screen Retainer	1
2			Ring, Shaft Retainer	1
3			Lever, Throttle	1
4			Cover, Metering Lever	1
5	C	*300456	Cover, Fuel Pump	1
	C	**300072	Cover, Fuel Pump	1
6			Shaft Assembly, Throttle	1
7			Valve, Throttle	1
8		③⑥	Shaft Assembly, Choke	1
9		③⑥	Valve, Choke	1
10		①	Valve, Inlet Needle	1
11			Seat Assembly, Check Valve	1
12		①④	Plug, Cup 5mm	1
13		①	Plug, Welch 5/16	1
14		③⑥	Ball, Choke Friction	1
15		①②④⑤	Gasket, Metering Diaphragm	1
16		①②④⑤	Gasket, Fuel Pump	1
17		①②④⑤	Diaphragm, Fuel Pump	1
18		①②④⑤	Diaphragm Assembly, Metering	1
19		①③⑥	Screw, Valve	3
20		①	Screw, Metering Lever Pin	1

ITEM NO.	STK CODE	PART NUMBER	DESCRIPTION	UNITS PER ASY.
21			Screw, Pump Cover	1
22			Screw, Idle Adjust Kit	1
23		①④	Screw, Metering Cover	4
24		③⑥	Spring, Choke Friction	1
25		①	Spring, Idle Needle	1
26		①	Spring, High Speed Needle	1
27		①	Spring, Throttle Return	1
28		①④	Spring, Metering Lever	1
29		①	Needle, High Speed	1
30		①	Needle, Idle	1
31		①	Screen, Check Valve	1
32		①④	Screen, Fuel Inlet	1
33		①④	Pin, Metering Lever	1
34		①④	Lever, Metering	1
*ZAMA ONLY				
**WALBRO ONLY				
①	B	300457	Kit, Carburetor Repair(Walbro)	
②	B	224460	Kit, Gasket/Diaphragm (Walbro)	
③	B	322363	Kit, Choke Lever(Walbro)	
④	C	300454	Kit, Carburetor Repair(Zama)	
⑤	C	300473	Kit, Gasket/Diaphragm(Zama)	
⑥	B	322358	Kit, Choke Lever(Zama)	

NOTE: Items are shown for identification and disassembly sequence purposes only. Components are not available separately unless a part number is listed before the part description.

CARBURETOR METERING LEVER ADJUSTMENT AND SETTINGS

CARBURETOR INLET POP OFF - 16-29 PSI

WALBRO - INLET

ZAMA - INLET

FLUSH WITH METERING CHAMBER FLOOR
FLUSH WITH TOP OF CARBURETOR BODY

FIGURE 4 SHAFT/HANDLE /CUTTER ASSEMBLY

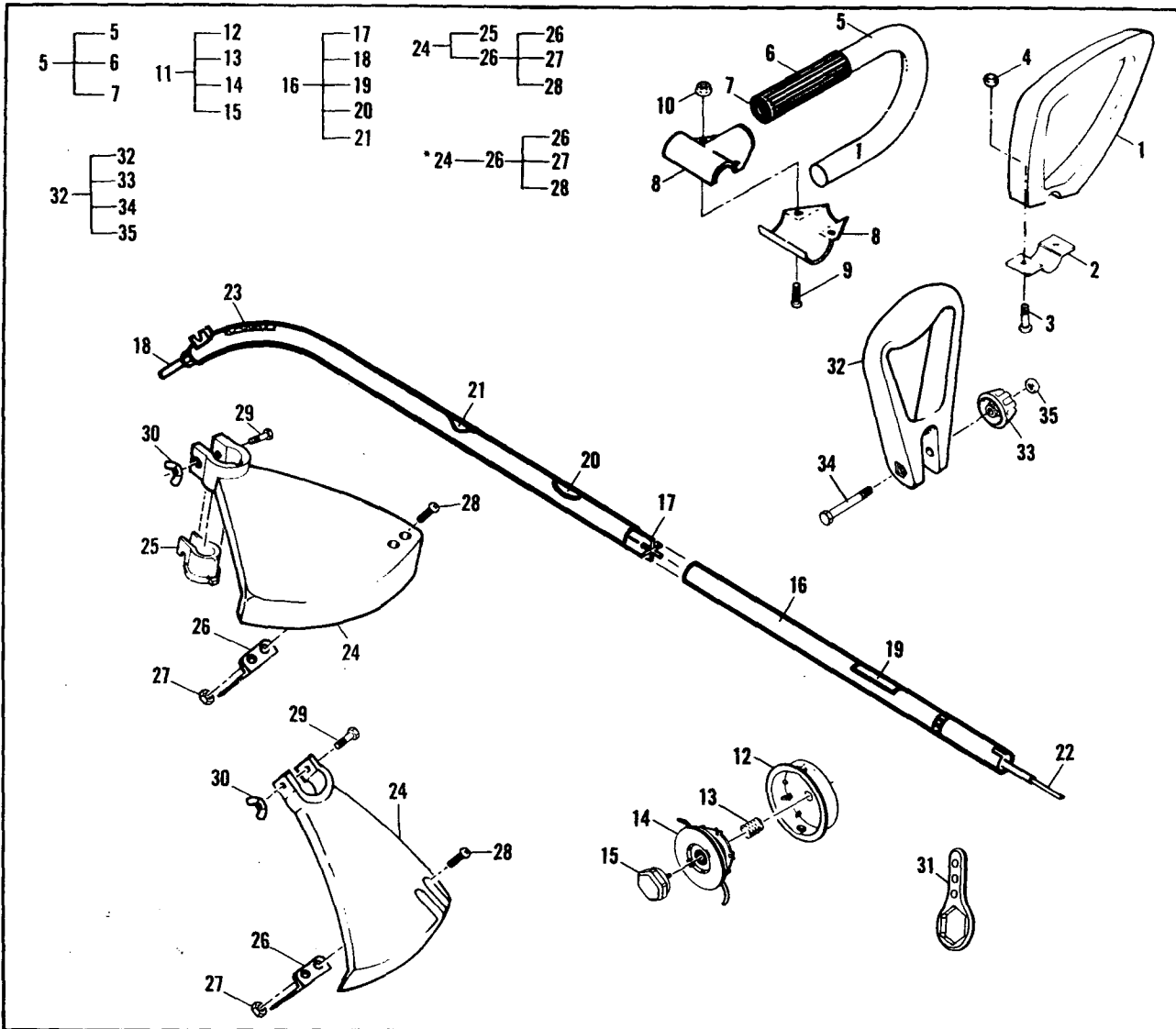

ITEM NO.	STK. CODE	PART NUMBER	DESCRIPTION	UNITS PER ASY.
1	A	217444	① Handle, Delta	1
2	A	217442	① Clamp, Handle	1
3	A	120041	① Screw, M5 x .8 x 22 Hex	2
4	A	217159	① Nut, Hex M5	2
5	C	300540	② Handle, "J" Grip Asy.	1
6	B	322139	. Grip	1
7	C	218328	. Plug, Tubing	1
8	A	215337	② Clamp, Handle	2
9	A	217935	② Screw, TR, 10-24 x .50 TORX	2
10	A	218315	② Nut	2
11	A	300651	Kit, Stringhead -Sml-	1
12	A	322025	. Housing/Eyelet Asy. w/Collar	1
13	A	322626	. Spring, Left	1
14	A	300688	. Kit, Line on Spool(M-Sm)	1
15	A	300736	. Kit, Knob Asy. -Sml-	1
16	C	300424	Housing Assembly, Outer (48")	1
17	---	---	. Sleeve	1
18	---	---	. Spindle	1

ITEM NO.	STK. CODE	PART NUMBER	DESCRIPTION	UNITS PER ASY.
19	B	218295	. Decal, Warning	1
20	B	223407	. Decal, Eye/Ear Cover	1
21	C	211214	. Decal, Warning(15m)	1
22	A	215324	Shaft, Flex	1
23	A	322099	Label, Debris Shield Warning	1
24	C	224062	* Shield Assembly, Grass 17"	1
	B	300317	③ Kit, Grass Shield Asy	1
25	C	224499	③ . Spacer	1
26	A	300626	. Kit, Knife	1
27	A	216682	.. Nut, Lock 10-24 Hex	2
28	A	217935	.. Screw, TR 10-24 x .50 Torx	2
29	A	216595	Screw, M6 x 1.0 Hex	1
30	A	111102	Nut, Wing, M6 x 1.0	1
31	T	322344	Wrench, Stringhead	1
32	B	300834	① Kit, Handle Assembly	1
33	B	322719	. Knob	1
34	B	09075-99	. Bolt, 1/4-20 x 2 1/2	1
35	B	13035-99	. Nut, 1/4-20 x .226T	1

- ① 12400128-02 ② 12400128-06 ③ 12400128-50
- 12400128-10 12400128-20
- 12400128-30 12400128-48
- 12400128-52 12400128-50

SPECIFICATIONS

ENGINE TYPE	Air-Cooled, Two Cycle, Single Chrome Cylinder
DISPLACEMENT	28 cc
MAXIMUM HORSEPOWER	1.1 hp.
BORE & STROKE	1.37 x 1.12 Inches (35 mm x 28.6 mm)
IDLE RPM	2,700 - 3,000 rpm, assembled
MAXIMUM RPM	7,000 - 8,000 rpm, assembled
COMPRESSION (PSI)	After 10 pulls, throttle full open: 80 lbs.
IGNITION	Solid State
FLYWHEEL to IGNITION GAP	0.010 to 0.015 inches(0.254 to 0.381 mm)
SPARK PLUG GAP & TYPE025 Inches(.63 mm)Champion DJ8J(RDJ8J-Canada)
FUEL TANK CAPACITY	23.3 oz.(690 ml)
FUEL TYPE	Unleaded - Regular Grade
FUEL TO OIL RATIO	40:1 McCulloch Custom Lubricant
DRY WEIGHT	13.6 Lbs.
CARBURETOR	Diaphragm/Primer Type
STARTER CORD	Nylon, Type 3.5, Length 46 in.

SERVICE TOOLS

PART NUMBER	DESCRIPTION
215432	PRESSURE TEST TOOL KIT, TORX WRENCHES T-25 TORX DRIVE 3.5"
217720	
222785	

TORQUE SPECIFICATIONS

DESCRIPTION	TORQUE VALUE(in.lbs.)	LOCTITE
CRANKCASE TO CYLINDER	55-60	YES
CRANKCASE TO PLASTIC PLUG	35-40	YES
INSULATOR TO CYLINDER	45-50	YES
SHROUD TO CRANKCASE	55-60	YES
IGNITION ASSEMBLY	45-50	YES
CARBURETOR	25-30	NO
STARTER HOUSING	30-35	NO
CLUTCH HOUSING	30-35	NO
FLYWHEEL NUT	140-145	NO
SPARK PLUG	120-125	NO

LOCTITE KIT

PART NUMBER	DESCRIPTION
322235	LOCTITE KIT RETAINING COMPOUND 620(10ml) THREAD LOCKER 242(10ml) GASKET ELIMINATOR 518(50ml) BLACK MAX ADHESIVE 380(1 oz)
322236	
322237	
322238	
322239	